



CE SGS RoHS cUL US E347821

Chinee Cable Tie Co.,Ltd.

Chinee Cable Tie Co.,Ltd.

china-cable-tie.com

china-cable-tie.com



ABOUT US

Chinese Cable Tie Co., Ltd, a subsidiary of Chinese Group Limited, is a professional manufacturer and exporter specializing in the research, development, and production of cable tie products. As an integrated supplier, we are committed to providing high-quality and diverse cable tie solutions to customers worldwide. With a strong focus on product quality and continuous innovation, we have earned the trust and recognition of clients across various industries and regions.

Equipped with advanced production facilities and a comprehensive quality management system, our product range includes nylon cable ties, stainless steel cable ties, releasable cable ties, marker ties, weather-resistant ties, colored ties, and more. These products are widely used in electrical installations, automotive applications, construction projects, packaging and logistics, gardening, and agriculture. All items comply with international quality and environmental standards to meet the needs of different global markets.

Chinese Cable Tie Co., Ltd also offers flexible OEM and ODM services. We can customize products based on clients' drawings, samples, or functional requirements,

With support from our experienced engineering and technical teams. From product design and prototyping to mass production and packaging, we provide a complete one-stop solution to ensure both reliability and competitiveness.

Upholding the business philosophy of "Quality First, Integrity-Based," we are dedicated to becoming a trusted long-term partner for clients around the world. We warmly welcome customers from all over the globe to contact us for cooperation and mutual success.

are
to



目录 Catalog

尼龙扎带系列 ————— 01-13
NYLON CABLE TIE SERIES

尼龙扎带包装系列 ————— 14-20
NYLON CABLE TIE PACKING SERIES

不锈钢扎带系列 ————— 21-30
STAINLESS STEEL CABLE TIE SERIES

扎带工具系列 ————— 31-32
TIE TOOL SERIES

接线端子系列 ————— 33-38
ELECTRICAL CONNECTOR SERIES

其他系列 ————— 39-43
OTHER SERIES

专业品质

Professional quality 追求卓越

The pursuit of excellence



01 自锁式尼龙扎带
Self-locking Nylon Cable Ties



03 锁片式尼龙扎带
Metal Pawl Nylon Cable Tie



04 固定式尼龙扎带
Mountable Head Cable Tie



05 可松式尼龙扎带
Reusable Cable Ties



06 双扣式尼龙扎带
Double Locking Cable Ties



07 标牌式尼龙扎带
Marker Nylon Cable Ties



07 特殊扎带
Special Cable Ties



08 双面齿扎带
Super Tensile Cable Ties



09 插销式尼龙扎带
Push Mount Cable Tie



10 杉树型汽车扎带
Auto Car Fir Tree Cable Tie



11 电缆扎带及紧固件
Cable Tie & Fasteners



12 魔术贴扎带
Hook and loop cable ties



14 尼龙扎带包装款式A&B系列
Racking Series A&B



15 尼龙扎带包装款式C系列
Packing Series C



17 尼龙扎带包装款式D系列
Packing Series D



19 不锈钢扎带-滚珠锁紧式
Naked Stainless Steel Cable Tie-ball Lock Type



20 白钢不锈钢扎带-盘带
Naked Stainless Steel Banding



21 不锈钢喷塑扎带-滚珠锁紧式
Epoxy Coated Stainless Steel Cable Tie-ball Lock Type



22 喷塑不锈钢扎带-L型
Epoxy Coated Stainless Steel Cable Tie-l Lock Type



22 喷塑不锈钢盘带
Epoxy Coated Stainless Steel Steel Banding



23 不锈钢扎带-漆膜型多重锁紧式
Pvc Covered Stainless Steel Tie-l Lock Type



23 白钢喷塑盘带
Pvc Covered Stainless Steel Banding



24 不锈钢喷塑扎带-O型锁紧式
Pvc Covered Stainless Steel Cable Tie-o Lock Type

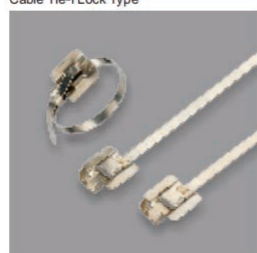

25 固定头式尼龙扎带
Mountable Head Ties



25 不锈钢喷塑扎带-可退式
Releasable Stainless Steel Cable Tie-epoxy Type



26 不锈钢扎带-阶梯型多重锁紧式
Stainless Steel Cable Tie-multi Lock Type



27 白钢喷塑扎带-阶梯型多重锁紧式
Epoxy Coated Stainless Steel Cable Tie-multi Lock Type



28 扎带工具 SYG01
Tie Tool Syg01



28 扎带工具 SYG02
Tie Tool Syg02



28 扎带工具 SYG03
Tie Tool Syg03



28 扎带工具 SYG04
Tie Tool Syg04



29 扎带工具 LQG-1
Tie Tool Lqg-1



29 扎带工具 LQG-2
Tie Tool Lqg-2



29 扎带工具 LQA
Tie Tool Lqa



29 扎带工具 JD1910
Tie Tool Jd1910



31 圆形预绝缘端子
Insulated Ring Terminal (rv Series)

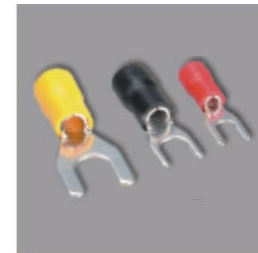

32 叉形绝缘端子
Insulated Spade Terminal (sv Series)



33 长形全卷圆中间接头
Long Full Insulated Middle Joint Terminal (but Connector By Series)



33 子弹型公预绝缘端子
Bullet-shaped Male Insulated Terminal (mpd Series)



34 子弹型母全绝缘端子
Bullet-shaped Female Insulated Terminal (frd Series)



34 螺旋式压线帽
Screw On Wire Connector

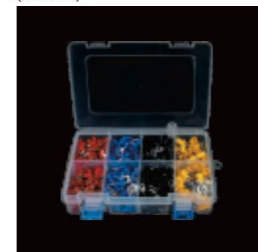

35 超值包装
Value Pack



37 螺丝固定座
Saddle Type Tie Mount

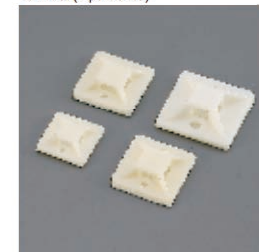

37 自粘式定位片
Self-adhesive Tie Mounts



38 圆形号码管
Circular Cable Markers



38 扁形号码管
Flat Cable Markers



38 号码管带
Cable Marker Strips



39 圆型(K型)钢钉线卡
Circle Cableclips (k Type)



39 扁型钢钉线卡
Flat Cable Clips



40 卷式捆束保护带(缠绕管)
Spiral Wrapping Bands



40 膨胀管
Expand Plugs

NYLON CABLE TIE SERIES

尼龙扎带系列



适用范围 Scope of Application

扎带广泛应用于捆扎电视机、电脑等内部连接线，灯饰、电机、电子玩具等产品内线路的固定，机械设备油路管道的固定，船舶上电缆线路的固定，自行车整车包装或捆绑其他物体，也可用于农业、园艺、手工艺品等捆扎物品。

Cable ties are widely used in banding internal connecting wires such as television, computer, lighting, electrical, electronic toys and other products; fixing mechanical equipment, oil pipe and cable lines on ships; bicycle vehicle packaging or other objects bundling, and also used in agriculture, horticulture, handicrafts and so on.

产品特点 PRODUCT FEATURES

材质：采用UL认可之尼龙66料制成，防火等级94V-2，耐酸、耐蚀、绝缘性良好，不易老化、承受力强。

颜色：标准颜色为本色(白色)，另有抗紫外线之黑色，特殊颜色欢迎订做。

Material: Nylon66, 94V-2 certificated by UL. Heat-resisting, erosion control, insulate well and not apt to age.

Color: Natural (or white, standard color) .UV black and other colors are available as requested.

- 自锁式尼龙扎带
Self-locking Nylon Cable Ties
- 特殊扎带
Special Cable Ties
- 镶片式尼龙扎带
Metal Pawl Cable Ties
- 双面齿扎带
Super Tensile Cable Ties
- 固定式尼龙扎带
Mountable Head Cable Tie
- 插销式尼龙扎带
Push Mount Cable Tie
- 可松式尼龙扎带
Reusable Cable Ties
- 杉树型汽车扎带
Auto Car Fir Tree Cable Tie
- 双扣式尼龙扎带
Double Locking Cable Ties
- 电缆扎带及紧固件
Cable Tie & Fasteners
- 标牌式尼龙扎带
Marker Nylon Cable Ties
- 魔术贴扎带
Hook and loop cable ties

NYLON CABLE TIE SERIES

尼龙扎带系列

CE SGS RoHS c UL US E347821



自锁式尼龙扎带 Self-locking Nylon Cable Ties

材质：采用UL认可之尼龙66料制成，防火等级94V-2，耐酸、耐蚀、绝缘性良好，不易老化、承受力强；

操作温度：-35℃~85℃；

颜色：标准颜色为本色（白色），另有抗紫外线之黑色，特殊颜色欢迎订做。

Material: Nylon 66 certificated by UL, flammability class 94V-2; Heat-resisting, anti-corrosion, good insulation and not easily aging;

Working temperature: -35℃ to 85℃;

Color: Natural (or white, standard color) UV black and other colors are available as requested.

型号 Item No.	长 L Length		厚 Thickness (mm)	宽 W Width (mm)	捆扎范围 E Bundle Diameter(mm)	承受力 Tensile Strength				
	Inch	mm				lbs	kgs			
SY1-1-25080	3 3/16"	80	1.1	2.5	2-16	18	8			
SY1-1-25100	4"	100	1.0		2-22					
SY1-1-25120	4 3/4"	120	1.1		2-30					
SY1-1-25150	6"	150	1.05		2-35					
SY1-1-25160	6 1/4"	160	1.05		2-40					
SY1-1-25200	8"	200	1.05	2-50	3.2	40	18			
SY1-1-32120	4 3/4"	120	1.1	3-30						
SY1-1-32150	6"	150	1.1	3-35						
SY1-1-36140	5 1/2"	140	1.2	3-33				3.6	40	18
SY1-1-36150	6"	150	1.2	3-35						
SY1-1-36180	7"	180	1.2	3-42						
SY1-1-36200	8"	200	1.2	3-50						
SY1-1-36250	10"	250	1.25	3-65						
SY1-1-36280	11"	280	1.25	3-70	4.8	50	22			
SY1-1-36300	11 5/8"	300	1.3	3-80						
SY1-1-36370	14 3/5"	370	1.35	3-105						
SY1-1-48120	4 3/4"	120	1.25	3-30						
SY1-1-48150	6"	150	1.25	3-35						
SY1-1-48160	6 1/4"	160	1.25	3-37						
SY1-1-48180	7"	180	1.25	3-42						
SY1-1-48190	7 1/2"	190	1.22	3-46						
SY1-1-48200	8"	200	1.3	3-50						
SY1-1-48250	10"	250	1.3	3-65						
SY1-1-48280	11"	280	1.3	3-70						
SY1-1-48300	11 5/8"	300	1.3	3-82						
SY1-1-48350	13 3/4"	350	1.3	3-90						
SY1-1-48370	14 3/5"	370	1.3	3-98						
SY1-1-48380	15"	380	1.3	3-102						
SY1-1-48400	15 3/4"	400	1.3	3-105						
SY1-1-48430	17"	430	1.35	3-110						
SY1-1-48450	17 3/4"	450	1.35	3-130						
SY1-1-48500	19 11/16"	500	1.4	3-150						

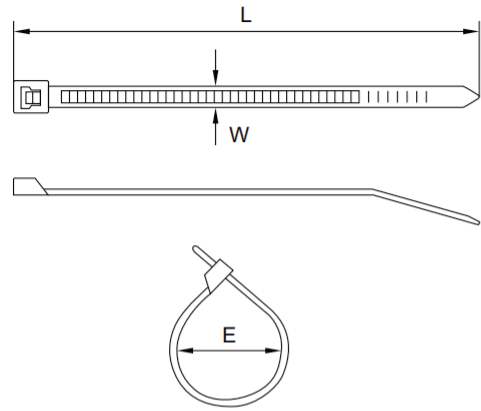

型号 Item No.	长 L Length		厚 Thickness (mm)	宽 W Width (mm)	捆扎范围 E Bundle Diameter(mm)	承受力 Tensile Strength				
	Inch	mm				lbs	kgs			
SY1-1-72150	6"	150	1.55	7.2	3-33	120	55			
SY1-1-72200	8"	200	1.55		3-50					
SY1-1-72250	10"	250	1.55		4-63					
SY1-1-72300	11 5/8"	300	1.6		4-82					
SY1-1-72350	13 3/4"	350	1.5		4-90					
SY1-1-72370	14 3/5"	370	1.5		4-98					
SY1-1-72380	15"	380	1.5		4-100					
SY1-1-72400	15 3/4"	400	1.5		4-105					
SY1-1-72450	17 3/4"	450	1.6		4-110					
SY1-1-72500	19 11/16"	500	1.6		4-150					
SY1-1-72530	20 3/4"	530	1.6		4-155					
SY1-1-72550	21 1/16"	550	1.6		4-160					
SY1-1-76200	8"	200	1.5		7.6			3-50	120	55
SY1-1-76250	10"	250	1.5					4-63		
SY1-1-76300	11 5/8"	300	1.5					4-82		
SY1-1-76350	13 3/4"	350	1.5	4-90						
SY1-1-76360	14.2"	360	1.5	4-94						
SY1-1-76380	15"	380	1.55	4-100						
SY1-1-76400	15 3/4"	400	1.5	4-105						
SY1-1-76450	17 3/4"	450	1.5	4-118						
SY1-1-76500	19 11/16"	500	1.5	4-150						
SY1-1-76550	21 1/16"	550	1.5	4-160						
SY1-1-76750	29 9/16"	750	1.6	4-220						
SY1-1-90400	15 3/4"	400	1.8	9		4-105	175	80		
SY1-1-90450	17 3/4"	450	1.8			8-118				
SY1-1-90500	19 11/16"	500	1.9			8-150				
SY1-1-90550	21 1/16"	550	1.9			8-160				
SY1-1-90600	23 5/8"	600	1.8		8-170					
SY1-1-90650	25 9/16"	650	1.8		8-190					
SY1-1-90700	27 1/2"	700	1.9		10-205					
SY1-1-90750	29 9/16"	750	1.9		10-220					
SY1-1-90800	31 1/2"	800	1.9		10-230					
SY1-1-90920	36 1/4"	920	1.9		10-265					
SY1-1-91020	40 1/6"	1020	1.95		10-295					
SY1-1-91200	47 1/4"	1200	1.95		10-340					
SY1-1-12600	23 5/8"	600	2.15		12	14-170			200	91
SY1-1-12650	25 9/16"	650	2.15			14-190				
SY1-1-12700	27 1/2"	700	2.15			14-205				
SY1-1-12750	29 9/16"	750	2.15	14-220						
SY1-1-12800	31.5"	800	2.15	14-235						
SY1-1-12900	35.5"	900	2.15	14-265						
SY1-1-121000	39 3/8"	1000	2.15	14-275						

NYLON CABLE TIE SERIES

尼龙扎带系列

CE SGS RoHS cUL US E347821



镶片式尼龙扎带 Metal Pawl Nylon Cable Tie

材质：采用UL认可的尼龙材料制成，防火等级94V2；
 性能：耐酸，耐蚀，绝缘性良好，不易老化，承受力强；
 安装温度：-10°C~85°C；
 工作温度：-30°C~85°C；
 颜色：标准颜色为本色(白色)，适合室内使用。黑色扎带加入炭黑与UV剂，可应用于室外。
 产品特性：高强度；操作简单方便；配备不同材料，适用于多种用途和使用环境。

Material: Polyamide 6.6 (PA66), Flammability UL94 V2;
 Properties: Acid resistance, corrosion resistance, good insulation, not easy to age, strong endurance;
 Installation temperature: -10°C~85°C;
 Working Temperature: -30°C~85°C;
 Color: White & Black(UV), colors can be customized;
 Product Description: Wide range of sizes are used for bundling and securing cables, pipes and hoses; Internal serrated straps for more stable strapping; Simple to operate, either manually or with machining tools; High Tensile Strength & Good Durability.

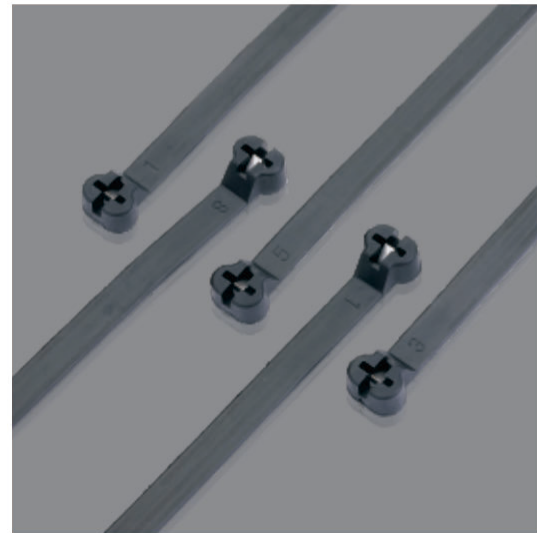
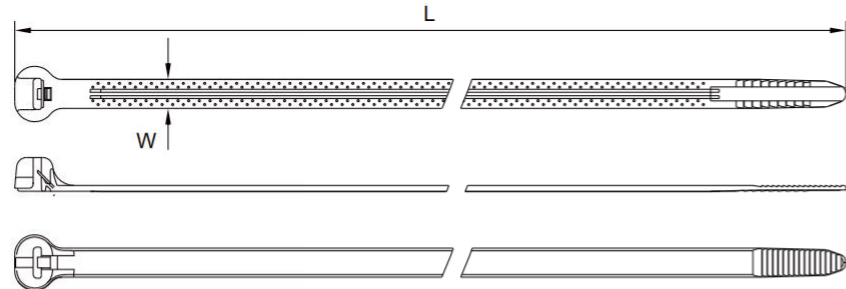

固定式尼龙扎带 Mountable Head Cable Tie

材质：采用UL认可的尼龙材料制成，防火等级94V2；
 性能：耐酸，耐蚀，绝缘性良好，不易老化，承受力强；
 安装温度：-10°C~85°C；工作温度：-30°C~85°C；
 颜色：标准颜色为本色(白色)，适合室内使用。黑色扎带加入炭黑与UV剂，可用于室外使用；
 产品特性：固定与系紧一体式设计；适用于复杂的应用。

Material: Polyamide 6.6 (PA66);
 Flammability: UL94 V2;
 Properties: Acid resistance, corrosion resistance, good insulation, not easy to age, strong endurance;
 Installation Temperature: -10°C~85°C; Working Temperature: -30°C~85°C;
 Color: White and black(UV), colors can be customized;
 Product Description: Integrated cable tie (Fixing & Fastening); Suitable for complex applications.

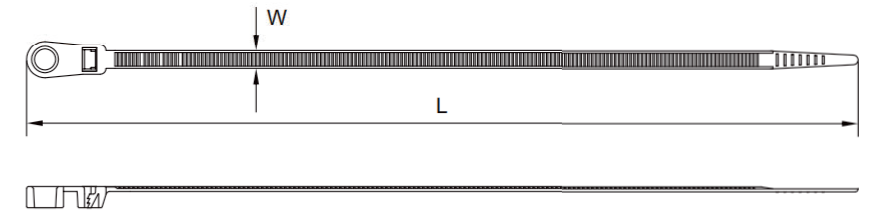

型号 Item No.	规格(W×L) Specification(mm)		有效长度 Effective Length (mm)	捆扎范围 Bundle Dia. (mm)	拉力(标准) Tensile Strength (STANDARD)	
	Width	Length			N	kgs
SY1-2-4150	4	150	120	35	180	40
SY1-2-4200		200	170	50		
SY1-2-5250	5	250	200	65	220	50
SY1-2-5300		300	260	80		
SY1-2-7145	7	145	115	35	500	112
SY1-2-7175		175	145	45		
SY1-2-7200		200	170	50		
SY1-2-7240		240	200	60		
SY1-2-7300		300	260	80		
SY1-2-7400		400	360	110		
SY1-2-10300	10	300	260	80	550	124
SY1-2-10350		350	310	95		
SY1-2-10400		400	360	110		
SY1-2-10450		450	410	130		
SY1-2-10550		550	510	160		
SY1-2-10600		600	560	175		

型号 Item No.	长 L Length		宽 W Width (mm)	(最大) 捆扎范围 Max. Bundle DIA. (mm)	承受力 Tensile Strength	
	Inch	mm			lbs	kgs
SY1-3-25100 T	4"	100	2.5	22	18	8
SY1-3-36100 T	4"	100	3.6	22	40	18
SY1-3-36150 T	6"	150	3.6	32	40	18
SY1-3-36200 T	8"	200	3.6	42	40	18
SY1-3-48200 T	8"	200	4.8	42	50	22

NYLON CABLE TIE SERIES

尼龙扎带系列

CE SGS RoHS cUL E347821



可松式尼龙扎带 Reusable Cable Ties

材质：采用UL认可的尼龙材料制成，防火等级94V2；
 性能：耐酸，耐蚀，绝缘性良好，不易老化，承受力强；
 安装温度：-10°C~85°C；工作温度：-30°C~85°C；
 颜色：标准颜色为本色(白色)，适合室内使用。黑色扎带加入炭黑与UV剂，可用于室外使用；
 产品特性：用于中等负载的可拆卸扎带；易于操作的解扣方式；适用于户外使用。

Material: Polyamide 6.6 (PA66), Flammability UL94 V2;
 Properties: Acid resistance, corrosion resistance, good insulation, not easy to age, strong endurance;
 Installation Temperature: -10°C~85°C; Working Temperature: -30°C~85°C;
 Color: White and black(UV), colors can be customized;
 Product Description: Releasable cable ties for medium load capacity; Easily assembled by hand or with pliers, remain securely locked until intentionally released by operating the finger catch; Suitable for outdoor usage.

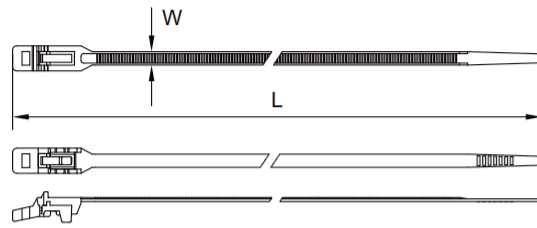

型号 Item No.	长 L Length		宽 W Width(mm)	捆扎范围 E Bundle Diameter (mm)	承受力 Tensile Strength	
	Inch	mm			lbs	kgs
SY1-4-48280	11"	280	4.8	60	40	18

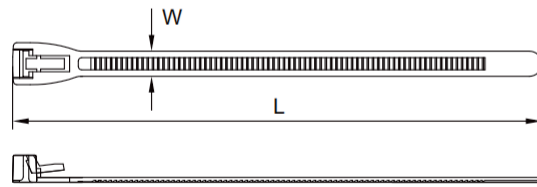

型号 Item No.	长 L Length		宽 W Width(mm)	捆扎范围 E Bundle Diameter (mm)	承受力 Tensile Strength	
	Inch	mm			lbs	kgs
SY1-4-72150	6"	150	7.2	35	50	22
SY1-4-72200	8"	200		50		
SY1-4-72250	10"	250		65		
SY1-4-72300	12"	300		80		

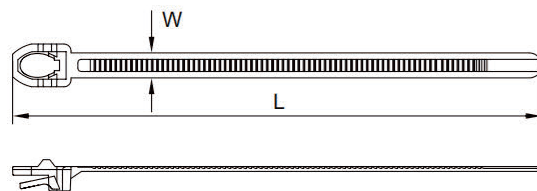

型号 Item No.	长 L Length		宽 W Width(mm)	捆扎范围 E Bundle Diameter (mm)	承受力 Tensile Strength	
	Inch	mm			lbs	kgs
SY1-4-72150	6"	150	7.2	35	50	22
SY1-4-72200	8"	200		50		
SY1-4-72250	10"	250		65		
SY1-4-72300	12"	300		80		



双扣式扎带 Double-locking Nylon Cable Tie

材质：采用UL认可的尼龙材料制成，防火等级94V2；
 性能：耐酸，耐蚀，绝缘性良好，不易老化，承受力强；
 安装温度：-10°C~85°C；工作温度：-30°C~85°C；
 颜色：标准颜色为本色(白色)，适合室内使用。黑色扎带加入炭黑与UV剂，可用于室外使用；
 特性：抗拉强度高；外齿设计，内表面光滑；保护电缆免受绝缘损坏；低平头优化设计，适用于狭小空间。

Material: Polyamide 6.6 (PA66), Flammability UL94 V2;
 Properties: Acid resistance, corrosion resistance, good insulation, not easy to age, strong endurance;
 Installation temperature: -10°C~85°C; Working Temperature: -30°C~85°C;
 Color: White & Black(UV), colors can be customized;
 Feature: High tensile strength; External tooth design, smooth inner surface; Protects cables from insulation damage; Optimized design with low flat head, suitable for narrow spaces.

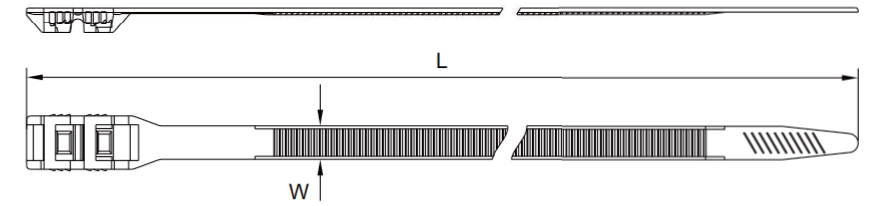

型号 Item No.	长 L Length		宽 W Width(mm)	最大捆径 Max. Bundle Dia. (mm)	拉力 Tensile Strength	
	Inch	mm			lbs	kgs
SY1-5-190DL	7"	190	9	45	67	30
SY1-5-250DL	10"	250	9	66	67	30
SY1-5-360DL	13 5/8"	360	9	90	67	30
SYE-5-1000DL	40"	1000	9	290	67	30

NYLON CABLE TIE SERIES

尼龙扎带系列

CE SGS RoHS cUL US E347821



标牌式尼龙扎带 Marked Nylon Cable Ties

材质：采用UL认可的尼龙材料制成，防火等级94V2；
性能：耐酸，耐蚀，绝缘性良好，不易老化，承受力强；
安装温度：-10°C~85°C；工作温度：-30°C~85°C；
颜色：标准颜色为本色(白色)，适合室内使用。黑色扎带加入炭黑与UV剂，可用于室外使用；
产品特性：扎带前端设有白标牌，可以放入标贴，可重复使用。

Material: Polyamide 6.6 (PA66), Flammability UL94 V2;
Properties: Acid resistance, corrosion resistance, good insulation, not easy to age, strong endurance;
Installation temperature: -10°C~85°C; Working Temperature: -30°C~85°C;
Color: White & Black(UV), colors can be customized.
Features: Marker Cable Ties enable wire and cable bundles to be fastened and identified at the same time.

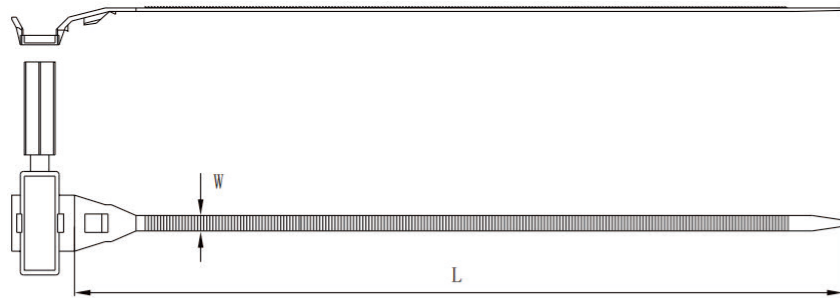

型号 Item No.	长 L Length		宽 W Width(mm)	最大捆径 Max. Bundle Dia. (mm)	拉力 Tensile Strength	
	Inch	mm			lbs	kgs
SY1-6-180MKT	7"	180	5	55	50	22
SY1-6-240MKT	9.4"	240	5	74	50	22



特殊扎带 Special Cable Ties

材质：采用UL认可尼龙66制成，防火等级94V-2，耐酸蚀，不易老化；
使用方法：先将机板钻孔，然后把扎带插入孔内，再将电线扎紧即可。

Material: Nylon 66, 94V-2 certified by UL. Acid-control, Not easy to age;
Usage: Insert tie to the hole of table and tighten it.

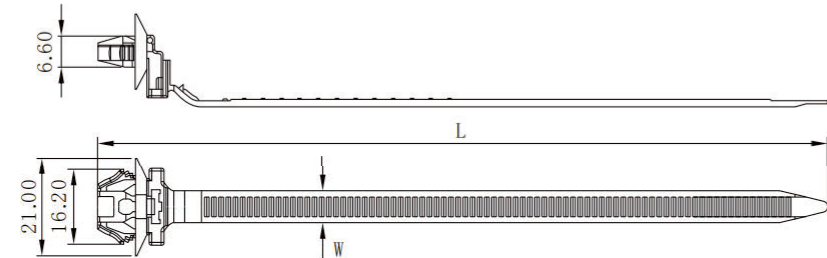

型号 Item No.	长 L Length		宽 W Width(mm)	最大捆径 Max. Bundle Dia. (mm)	拉力 Tensile Strength	
	Inch	mm			lbs	kgs
SY1-7-155A	6.1"	155	7.0	35	50	22
SY1-7-155B	6.1"	155	7.0	35	50	22

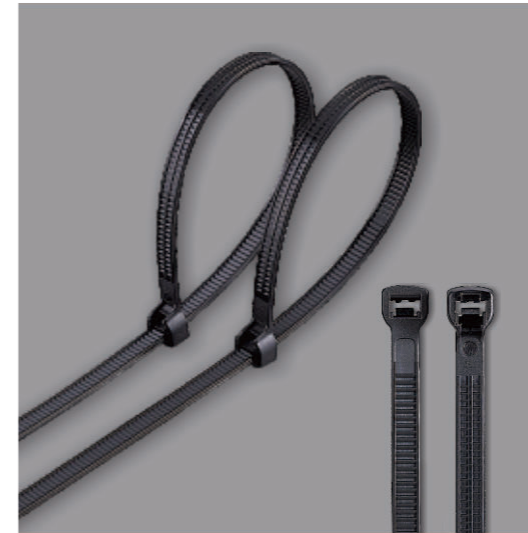

双面齿扎带 Super Tensile Strength Cable Tie

材质：采用UL认可的尼龙材料制成，防火等级94V2；
性能：耐酸，耐蚀，绝缘性良好，不易老化，承受力强；
安装温度：-10°C~85°C；
工作温度：-30°C~85°C；

颜色：标准颜色为本色(白色)，应用于室内。黑色扎带加入炭黑与UV剂，可应用于室外；
产品特性：外观专利设计，专利号(004150779-0001)；双面齿设计，头部两边锁紧与固定，牙齿坚固不会坏，防震；可以提供持久扎带性能；锁力强，穿入力小，易于操作。

Material: Polyamide 6.6 (PA66), Flammability UL94 V2;
Properties: Acid resistance, corrosion resistance, good insulation, not easy to age, strong endurance;
Installation temperature: -10°C~85°C;
Working Temperature: -30°C~85°C;
Color: White & Black(UV), colors can be customized;
Product Description: Appearance Patent Design, Patent No. (004150779-0001); Double-sided tooth design, locking and fixing on both sides, the teeth are firm and will not be damaged; Strong locking force, low penetration force, easy to operate.

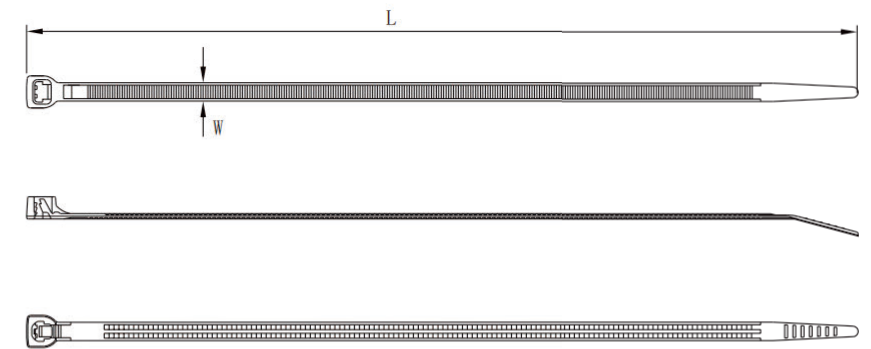

型号 Item No.	长 L Length		宽 W Width(mm)	最大捆径 Max. Bundle Dia. (mm)	拉力 Tensile Strength	
	Inch	mm			lbs	kgs
SY1-8-36200	8"	200	3.6	50	50	22
SY1-8-36250	10"	250	3.6	65	50	22
SY1-8-36300	11 5/8"	300	3.6	80	50	22
SY1-8-48180	7"	180	4.8	42	60	27
SY1-8-48200	8"	200	4.8	50	60	27
SY1-8-48280	11"	280	4.8	70	60	27
SY1-8-48300	11 5/8"	300	4.8	82	60	27

NYLON CABLE TIE SERIES

尼龙扎带系列



插销式尼龙扎带 Push Mount Cable Tie

材质：采用UL认可的尼龙材料制成，防火等级94V2；
 性能：耐酸，耐蚀，绝缘性良好，不易老化，承受力强；
 安装温度：-10°C~85°C；
 工作温度：-30°C~85°C；
 颜色：标准颜色为本色(白色)，应用于室内。黑色扎带加入炭黑与UV剂，可应用于室外；
 产品特性：箭头设计，轻松锁紧；扎带头始终处于固定位置；无需使用任何工具可轻松安装。
 Material: Polyamide 6.6 (PA66), Flammability UL94 V2;
 Properties: Acid resistance, corrosion resistance, good insulation, not easy to age, strong endurance;
 Installation temperature: -10°C~85°C;
 Working Temperature: -30°C~85°C;
 Color: White and black(UV), colors can be customized;
 Product Description: Arrow design, easy to lock; The cable tie head is always in the fixed position; Easy installation without tools.

A头型 A Type

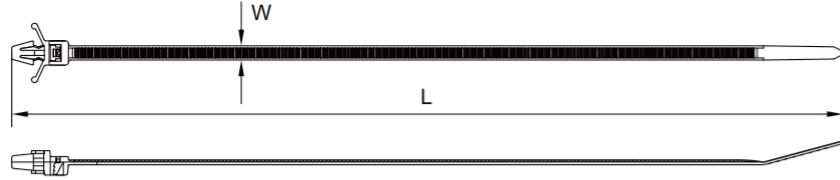

型号 Item No.	长 L Length		宽 W Width (mm)	(最大) 捆扎范围 Max. Bundle DIA. (mm)	拉力 Tensile Strength		孔径(φ) Hole Dia. (mm)	机板厚度 Panel Thickness (mm)
	Inch	mm			lbs	kgs		
SY1-8-100PT	4"	100	2.5	22	18	8	4.8	1.8
SY1-8-130PT	5.1"	140	3.6	30	40	18	4.6	1.8
SY1-8-150PT	6"	160	3.6	35	40	18	4.6	1.8
SY1-9-36200	8"	200	3.6	53	40	18	5	1.5
SY1-9-48200	8"	200	4.8	48	50	22	6	2

B头型 B Type

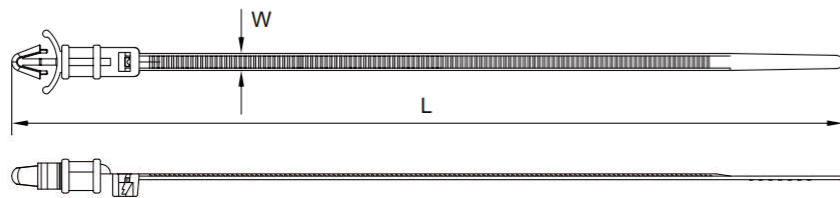

型号 Item No.	长 L Length		宽 W Width (mm)	(最大) 捆扎范围 Max. Bundle DIA. (mm)	拉力 Tensile Strength		孔径(φ) Hole Dia. (mm)	机板厚度 Panel Thickness (mm)
	Inch	mm			lbs	kgs		
SY1-8-150LPT	6"	170	3.6	35	40	18	4.6	2

CE SGS RoHS cUL US E347821



杉树型汽车扎带 Auto Car Fir Tree Cable Tie

材质：采用UL认可的尼龙材料制成，防火等级94V2；
 性能：耐酸，耐蚀，绝缘性良好，不易老化，承受力强；
 安装温度：-20°C~105°C；工作温度：-40°C~105°C；
 颜色：标准颜色为本色(白色)，适合室内使用。黑色扎带加入炭黑与UV剂，可用于室外使用；
 产品特性：安装方便，无需工具；圆盘扎带从各个方向调整压力，减少灰尘和水进入；内里表面光滑的外齿形电缆扎带，对电线电缆伤害小；杉树头部分可用于各种面板厚度。适用于螺纹孔。
 Material: Polyamide 6.6 (PA66), Flammability UL94 V2;
 Properties: Acid resistance, corrosion resistance, good insulation, not easy to age, strong endurance;
 Installation Temperature: -20°C~105°C; Working Temperature: -40°C~105°C;
 Color: White and black(UV), colors can be customized;
 Product Feature: Easy installation, no tools required; Disc ties adjust pressure from all directions to reduce dust and water ingress; With smooth surface inside, protect the cable from damage; Suitable for threaded holes.

A头型 A Type

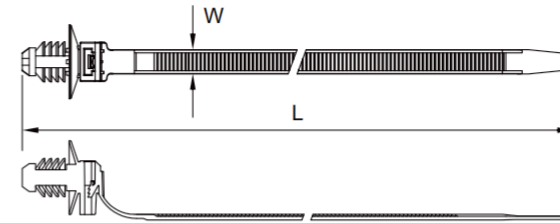

型号 Item No.	宽 Width (mm)	长 Length (mm)	厚 Thickness (mm)	孔径(φ) Hole Dia. (mm)	面板厚度 Panel Thickness (mm)	捆扎范围 Bundle DIA. (mm)	承受力 Tensile Strength	
							lbs	kgs
SY1-8-55185	5.5	185	1.25	6.0~8.0	1.0~6.0	3.5~43	50	22

B头型 B Type

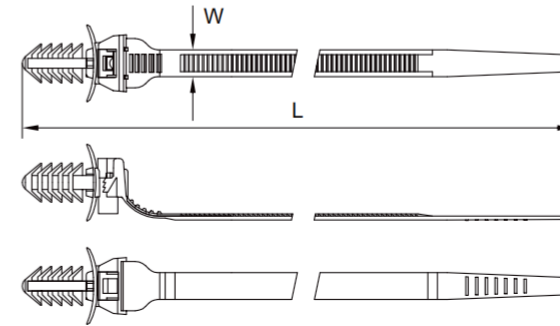

型号 Item No.	长 L Length		宽 W Width (mm)	(最大) 捆扎范围 Max. Bundle DIA. (mm)	拉力 Tensile Strength		孔径(φ) Hole Dia. (mm)	机板厚度 Panel Thickness (mm)
	Inch	mm			lbs	kgs		
SY1-8-140ST	5.5"	140	5.5	25	50	22	6	2.3
SY1-8-190ST	7.5"	190	5.5	45	50	22	6	2.3

C头型 C Type

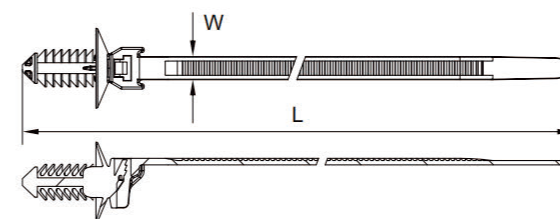

型号 Item No.	宽 Width (mm)	长 Length (mm)	厚 Thickness (mm)	孔径(φ) Hole Dia. (mm)	面板厚度 Panel Thickness (mm)	捆扎范围 Bundle DIA. (mm)	承受力 Tensile Strength	
							lbs	kgs
SY1-8-48170	4.8	170	1.35	6.5~7.0	0.4~10	3~39	50	22

NYLON CABLE TIE SERIES

尼龙扎带系列

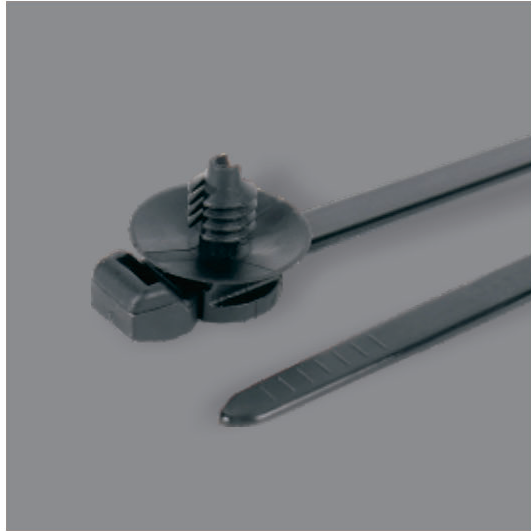

电缆扎带及紧固件 Cable Tie & Fasteners

材质：采用UL认可的尼龙材料制成，防火等级94V2；
 性能：耐酸，耐蚀，绝缘性良好，不易老化，承受力强；
 安装温度：-10℃~105℃；工作温度：-30℃~105℃；
 颜色：标准颜色为本色(白色)，适合室内使用。黑色扎带加入炭黑与UV剂，可用于室外使用；
 特点：扎带和杉树形固定头及配件，可预先安装；捆绑后扎带头部能够移动；易于安装，无需使用工具。

Material: Polyamide 6.6 (PA66), Flammability: UL94 V2;
 Properties: Acid resistance, corrosion resistance, good insulation, not easy to age, strong endurance;
 Installation Temperature: -10℃~105℃; Working Temperature: -30℃~105℃;
 Color: White and black(UV), colors can be customized;
 Product Properties: Cable ties and fir tree head assemblies, pre-installed; The head of the cable tie can move after binding; Easy to install, no tools required; Fir tree-shaped fixed head can be applied to a variety of plate thicknesses; Suitable for threaded holes.

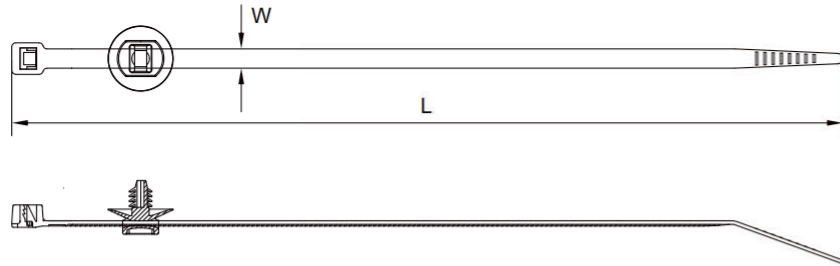

型号 Item No.	孔径(φ) Hole Dia. (mm)	面板厚度 Panel Thickness (mm)	应用范围 Application Range (mm)
SY1-9-5D	5	0.7-4.0	4.8

CE SGS RoHS cUL US E347821



魔术贴扎带 Hook and loop cable ties

Reusable hook and loop cable ties

材料：母面由PP制成，公面由尼龙制成。
 宽度：10-25mm；长度：100-400mm；厚度：1.3mm；
 应用：魔术贴扎带为粘贴式设计，有多种长度选择，整卷设计，可根据客户自身需求剪裁使用，灵活方便美观。
 特征：可重复使用；适用于捆绑网线(UTP/STP/Fiber)、信号线、电源线，避免尼龙扎带过紧影响传输速率。

Material: Female side is made of PP, male side is made of Nylon;
 Width: 10-25mm; Length: 100-400mm; Thickness: 1.3mm;
 Application: The Velcro cable tie is a pasting design, with a variety of length options, and a full roll design, which can be cut and used according to the customer's own needs, which is flexible, convenient and beautiful;
 Feature: Reusable; suitable for bundling LAN cable(UTP/STP/Fiber), signal line, power line, avoiding the transmission rate effected by nylon cable tie of tightening too much;
 Recommend widely used sizes as table:

型号 Item No.	长 L Length	宽 W Width(mm)	最大捆径 Max. Bundle Dia. (mm)	备注 Note
SYE-125MGT	125	12	30	Other sizes are available as requested.
SYE-135MGT	135		33	
SYE-150MGT	150		35	
SYE-180MGT	180	16	40	
SYE-210MGT	210		50	
SYE-250MGT	250		65	
SYE-310MGT	310	16	85	
SYE-400MGT	400		105	
SYE-500MGT	500		145	



Back to Back hook and loop roll type

材质：母面由PP制成，公面由尼龙制成；
 宽度：10-25mm；长度：0.2-50m；厚度：1.3mm；
 颜色：黑色，白色，红色，黄色，蓝色，绿色，特殊颜色可以定制，可定染；
 特点：薄软不伤线材，横向力度强。适用温度-30度到120度。

Material: Polyester base with Nylon loop or 100% Nylon;
 Width: 10-25mm;
 Length: 0.2-50m;
 Thickness: 1.3mm;
 Features: perforated available; soft, adjustable, logo printed customized;
 Usage: Bags, garments, books, wires;
 Color: white, black, red, yellow, blue, green and other colors available.

NYLON CABLE TIE PACKING SERIES

尼龙扎带包装系列



CE SGS RoHS cUL US E347821

尼龙扎带包装款式A&B系列 PACKING SERIES A&B



规格 Item (mm)	数量/外箱 Qty/CTN (bags)	毛/净重 G/N (kgs)	外箱尺寸 Outer Carton (cm)	内盒尺寸 Inner Box (cm)
2.5×80	600	14/16	52×40×30	38×25×28
2.5×100	500	14/16	52×40×32	38×25×30
2.5×120	500	17/19	52×40×32	38×25×30
2.5×150	400	16/18	52×40×32	38×25×30
2.5×160	400	17/19	52×40×32	38×25×30
2.5×200	250	14/16	52×40×30	25×38×28
2.5×200	300	16/18	52×40×34	25×38×32
3.6×140	250	17/19	52×40×32	38×25×30
3.6×150	250	17.5/19.5	52×40×36	38×25×34
3.6×180	200	15/17	52×40×30	38×25×28
3.6×200	200	17.5/19.5	52×40×34	38×25×30
3.6×250	150	16.5/18.5	52×40×30	38×25×28
3.6×280	150	18/20	52×40×30	38×25×28
3.6×300	125	17/19	52×40×32	38×25×30
3.6×370	100	18/20	52×40×28	50×19×26
4.8×120	200	15/17	52×40×32	38×25×30
4.8×150	150	14/16	52×40×28	38×25×26
4.8×180	150	15/17	52×40×30	38×25×28
4.8×190	150	17/19	52×40×32	38×25×30
4.8×200	125	15/17	52×40×30	25×38×28
4.8×200	150	18/20	52×40×32	25×38×32
4.8×250	125	18/20	52×40×32	25×38×30
4.8×280	100	17/19	52×40×30	25×38×28
4.8×300	100	18/20	52×40×32	50×19×30
4.8×350	80	17/19	52×40×30	50×19×28
4.8×370	80	18/20	52×40×30	50×19×28
4.8×380	80	18/20	52×40×30	50×19×28
4.8×400	80	19/21	52×40×32	50×19×30
4.8×430	50	14/16	52×40×25	50×19×23
4.8×450	50	14.5/16.5	52×40×25	50×19×23
4.8×500	50	15/17	64×32×26	62×30×12
7.2×200	80	19/21	52×40×32	25×38×30
7.2×250	50	15/17	52×40×28	50×19×23
7.2×300	50	17/19	52×40×32	50×19×30
7.2×350	40	15/17	52×40×28	50×19×26
7.2×370	40	16/18	52×40×28	50×19×26
7.2×380	40	17.5/19.5	52×40×28	50×19×26
7.2×400	40	18/20	52×40×30	50×19×28
7.2×450	25	13/15	64×32×26	62×30×12
7.2×450	40	20/21	64×32×34	62×30×16
7.2×500	25	14/16	64×32×26	62×30×12
7.2×550	25	15/17	64×32×28	62×30×13
9×400	30	16/18	52×40×32	50×19×30
9×450	20	14/16	58×42×25	56×20×23
9×500	20	15/17	60×40×25	58×19×24
9×550	20	16/18	65×40×25	63×19×24
9×600	10	9/11	70×34×15	68×16×14
9×650	10	11/12	75×34×15	73×16×14
9×700	10	11.5/13.5	80×34×15	78×16×14
9×750	10	12/14	85×34×15	83×16×14
9×800	10	12.5/14	90×34×15	88×16×14
9×900	10	14.5/16	100×34×15	108×16×14
9×1000	10	14.5/16	110×34×15	108×16×14
9×1100	10	14.5/16	120×34×15	118×16×14
9×1200	10	14.5/16	130×34×15	128×16×14
12×600	10	13.5/15	70×34×24	68×16×23
12×650	10	15/16.5	75×34×24	73×16×23
12×900	10	18/20	100×34×25	98×16×24

NYLON CABLE TIE PACKING SERIES

尼龙扎带包装系列

CE SGS RoHS c.  US E347821

尼龙扎带包装款式C系列 PACKING SERIES C



500PCS PACKING

型号 Item No.	C7-500	
DETAIL	2.5×100MM 4"	300PCS
	3.6×200MM 8"	200PCS
MEAS.	41×41×48CM	
QTY	50 SETS/CTN (25 SETS/INNER BOX) 17300 SETS/20' CONTAINER	
G.W/N.W	15/13 KGS	
KEEVE	DIA: Φ7.5CM, HEIGHT: 21CM	



250PCS PACKING

型号 Item No.	C8-250	
DETAIL	2.5×100MM 4"	100PCS
	2.5×150MM 6"	100PCS
	3.6×200MM 8"	50PCS
MEAS.	42×31×48CM	
QTY	70 SETS/CTN (20 SETS/INNER BOX) 31300 SETS/20' CONTAINER	
G.W/N.W	11/10 KGS	
KEEVE	DIA: Φ5.5CM, HEIGHT: 21CM	



500PCS PACKING

型号 Item No.	C9-500	
DETAIL	2.5×100MM 4"	200PCS
	2.5×150MM 6"	200PCS
	4.8×200MM 8"	50PCS
	4.8×300MM 12"	50PCS
MEAS.	57×39×48CM	
QTY	48 SETS/CTN (24 SETS/INNER BOX) 8700 SETS/20' CONTAINER	
G.W/N.W	15/13 KGS	
KEEVE	DIA: Φ10CM, HEIGHT: 31CM	

尼龙扎带包装款式C系列 PACKING SERIES C



1200PCS PACKING

型号 Item No.	C10-1200	
DETAIL	2.5×100MM 4"	500PCS
	3.6×150MM 6"	200PCS
	4.8×200MM 8"	400PCS
	4.8×300MM 12"	100PCS
MEAS.	63×38×33CM	
QTY	15 SETS/CTN 5200 SETS/20' CONTAINER	
G.W/N.W	18/16 KGS	
KEEVE	DIA: Φ10CM, HEIGHT: 31CM	



1000+1PCS PACKING

型号 Item No.	C11-1000+1	
DETAIL	2.5 × 100 M " 4	500PCS
	2.5 × 150 M " 6	100PCS
	3.6 × 200 M " 8	300PCS
	3.6 × 300 M " 12	100PCS
	SYG 01 SET (GN)	1PC
MEAS.	63 × 38 × 33 CM	
QTY	15 SETS/CTN 5200 SETS/20' CONTAINER	
G.W/N.W	15/13 KGS	
KEEVE	DIA: Φ10CM, HEIGHT: 31CM	



150PCS PACKING

型号 Item No.	C12-150	
DETAIL	2.5 × 100 M " 4	100PCS
	3.6 × 200 M " 8	50PCS
MEAS.	42 × 38 × 33 CM	
QTY	70 SETS/CTN (35 SETS/INNER BOX) 31300 SETS/20' CONTAINER	
G.W/N.W	10/8 KGS	
KEEVE	DIA: Φ6CM, HEIGHT: 12CM	

NYLON CABLE TIE PACKING SERIES

尼龙扎带包装系列

尼龙扎带包装款式D系列 PACKING SERIES D



200PCS PACKING

型号 Item No.	D1-200	
DETAIL	2.5×100MM 4"	200PCS
MEAS.	61×37×38CM	
QTY	100 SETS/CTN (50 SETS/INNER BOX)	
G.W/N.W	11/9 KGS	



75PCS PACKING

型号 Item No.	D2-75	
DETAIL	2.5×100MM 4"	25PCS
	4.8×120MM 4.7"	25PCS
	4.8×200MM 8"	25PCS
MEAS.	61×37×38CM	
QTY	100 SETS/CTN	
G.W/N.W	12/10 KGS	



150PCS PACKING

型号 Item No.	D3-150	
DETAIL	2.5×100MM 4"	50PCS
	2.5×150MM 6"	50PCS
	3.6×200MM 8"	50PCS
MEAS.	54×32×32CM	
QTY	80 SETS/CTN	
G.W/N.W	9/7 KGS	

STAINLESS STEEL CABLE TIE SERIES

不锈钢扎带系列



STAINLESS STEEL CABLE TIE SERIES

不锈钢扎带系列

CE SGS RoHS cUL US E347821



不锈钢扎带-滚珠锁紧式

NAKED STAINLESS STEEL CABLE TIE-BALL LOCK TYPE

材质：采用不锈钢材质304, 316;
特性：耐酸、耐腐蚀、抗张强度高，使用简单快捷；
工作温度范围：-60°C~150°C；
各种长度皆可制作，特殊规格可按客户样品制作。

Material: SS304, 316;
Features: high acid resistance, corrosion resistance and tensile strength; easy and convenient operation;
Working temperature: -60°C~150°C;
Different lengths are available, special products can be made according to customer's sample.

型号 Item No.	规格 Specification (mm)	最大捆径 Max. Bundle Dia. (mm)	厚度 Thickness (mm)	包装 Packing
SY2-1-46100	4.6×100	23	0.25	100PCS/Bag
SY2-1-46150	4.6×150	38		
SY2-1-46200	4.6×200	52		
SY2-1-46250	4.6×250	63		
SY2-1-46300	4.6×300	82		
SY2-1-46350	4.6×350	95		
SY2-1-46400	4.6×400	116		
SY2-1-46500	4.6×500	125		
SY2-1-46600	4.6×600	154		
SY2-1-8150	8.0×150	38		
SY2-1-8200	8.0×200	52		
SY2-1-8250	8.0×250	63		
SY2-1-8300	8.0×300	82		
SY2-1-8350	8.0×350	95		
SY2-1-8400	8.0×400	114		
SY2-1-8500	8.0×500	125		
SY2-1-8600	8.0×600	154		
SY2-1-12250	12×250	64	0.30	
SY2-1-12300	12×300	82		
SY2-1-12400	12×400	110		
SY2-1-12500	12×500	140		
SY2-1-12600	12×600	154		

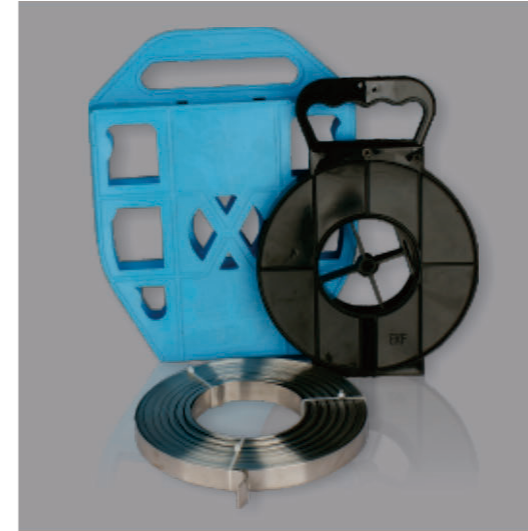

白钢不锈钢扎带-盘带

NAKED STAINLESS STEEL BANDING

材质：采用不锈钢材质304, 316;
特性：耐酸、耐腐蚀、抗张强度高，使用简单快捷；
工作温度范围：-60°C~150°C；
各种长度皆可制作，特殊规格可按客户样品制作。

Material: SS304, 316;
Features: high acid resistance, corrosion resistance and tensile strength; easy and convenient use;
Working temperature: -60°C~150°C;
Different lengths are available, special products can be made according to customer's sample.

型号 Item No.	宽度 Width		厚度 Thickness	应用范围 Application
	Inches	mm	mm	
SY2-2-0638	1/4	6.5	0.38	Number plate, a small attachment fixed, cable wires bundling
SY2-2-0938	3/8	9.5	0.38	Number cards, billboards, cable wire bundling
SY2-2-1060	3/8	10.0	0.60	Small billboards fixed junction box, pipe insulation bundling
SY2-2-1360	1/2	13.0	0.60	Insulation pipes, cable signal boxes, small control box
SY2-2-1660	5/8	16.0	0.60	Small road signs, cables, thin wall hose fixing
SY2-2-0960	3/4	19.0	0.60	Pole object, tube and flange connection
SY2-2-1076	3/8	10.0	0.76	Pole object such as junction box, signal box fixing
SY2-2-1376	1/2	12.7	0.76	Pipe connection and ordinary object bundled installing
SY2-2-1676	5/8	16.0	0.76	Pipe fixing, power system and pole equipment installing
SY2-2-1976	3/4	19.0	0.76	Heavy object fixing and bundling, sign of signal lights fixing
SY2-2-2612	1	25.0	0.76	Pole equipment bundling and fixing

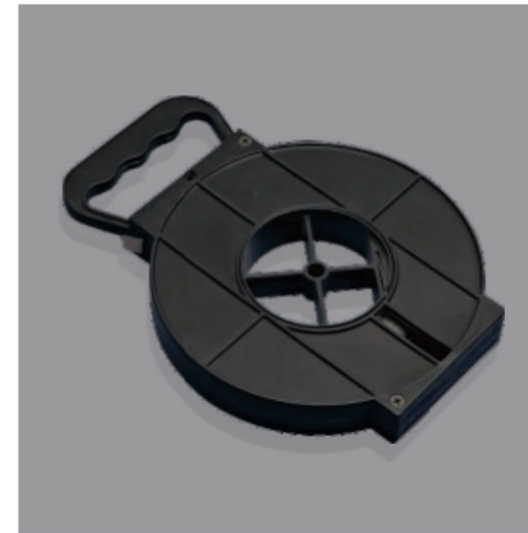

STAINLESS STEEL CABLE TIE SERIES

不锈钢扎带系列

CE SGS RoHS c TÜV US E347821



不锈钢喷塑扎带-滚珠锁紧式

EPOXY COATED STAINLESS STEEL CABLE TIE-BALL LOCK TYPE

材质：采用不锈钢材质304, 316；外喷环氧树脂热固性粉末涂料；

特性：耐酸、耐腐蚀、抗张强度高，使用简单快捷；

工作温度范围：-40°C~85°C；

各种长度皆可制作，特殊规格可按客户样品制作。

Material: SS304,316; Epoxy powder coated;

Features: high acid resistance, corrosion resistance and tensile strength; easy and convenient use;

Working temperature: -40°C~85°C;

Different lengths are available, special products can be made according to customer's sample.

型号 Item No.	规格 Specification (mm)	最大捆径 Max. Bundle Dia. (mm)	厚度 Thickness (mm)	包装 Packing
SY2-3-46100	4.6×100	23	0.35	100PCS/Bag
SY2-3-46150	4.6×150	38		
SY2-3-46200	4.6×200	52		
SY2-3-46250	4.6×250	63		
SY2-3-46300	4.6×300	82		
SY2-3-46350	4.6×350	95		
SY2-3-46400	4.6×400	116		
SY2-3-46500	4.6×500	125		
SY2-3-46600	4.6×600	154		
SY2-3-8150	8.0×150	38		
SY2-3-8200	8.0×200	52		
SY2-3-8250	8.0×250	63		
SY2-3-8300	8.0×300	82		
SY2-3-8350	8.0×350	95		
SY2-3-8400	8.0×400	114		
SY2-3-8500	8.0×500	125		
SY2-3-8600	8.0×600	154		
SY2-3-12250	12×250	64		
SY2-3-12300	12×300	82		
SY2-3-12400	12×400	110		
SY2-3-12500	12×500	140		
SY2-3-12600	12×600	154		



喷塑不锈钢扎带-L型

EPOXY COATED STAINLESS STEEL CABLE TIE-L LOCK TYPE

材质：采用不锈钢材质304, 316；外喷环氧树脂热固性粉末涂料；

特性：耐酸、耐腐蚀、不易燃烧，抗张强度高，使用简单快捷；

工作温度范围：-40°C~85°C；

各种长度皆可制作，特殊规格可按客户样品制作。

Material: SS304, 316; Epoxy powder coated;

Features: high acid resistance, corrosion resistance and tensile strength; non-flammable; easy and convenient use;

Working temperature: -40°C~85°C;

Different lengths are available, special products can be made according to customer's sample.

型号 Item No.	规格 Specification (mm)	最大捆径 Max. Bundle Dia. (mm)	厚度 Thickness (mm)	包装 Packing
SY2-4-12200	12×200	47	0.40	100PCS/Bag
SY2-4-12300	12×300	79		
SY2-4-12400	12×400	110		
SY2-4-12500	12×500	140		
SY2-4-16300	16×300	78		
SY2-4-16400	16×400	110		50PCS/Bag
SY2-4-16500	16×500	140		
SY2-4-16600	16×600	175		
SY2-4-16800	16×800	235		

喷塑不锈钢盘带

EPOXY COATED STAINLESS STEEL BANDING

材质：采用不锈钢材质304, 316；外喷环氧树脂热固性粉末涂料；

特性：耐酸、耐腐蚀、不易燃烧，抗张强度高，使用简单快捷；

工作温度范围：-40°C~85°C；

各种长度皆可制作，特殊规格可按客户样品制作。

Material: SS304, 316; Epoxy powder coated;

Features: high acid resistance, corrosion resistance and tensile strength; non-flammable; easy and convenient use;

Working temperature: -40°C~85°C;

Different lengths are available, special products can be made according to customer's sample.



型号 Item No.	宽度 Width		厚度 Thickness (mm)	配套搭扣 Matched Buckle	配套工具 Supporting Tool	包装数量 Packing Qty
	Inch	mm				
SY2-5-0930	3/8	9.0	0.35	L-10	LQA	30M
SY2-5-1225	1/2	12.0	0.40	L-12.0-12	LQA	25M
SY2-5-1625	5/8	16.0	0.40	L-16.0-16	LQA	25M

STAINLESS STEEL CABLE TIE SERIES

不锈钢扎带系列

CE SGS RoHS c TÜV US E347821



不锈钢包塑扎带-L型

PVC COVERED STAINLESS STEEL TIE-L LOCK TYPE

材质：采用不锈钢材质304, 316；外包PVC电缆料；
特性：耐酸、耐腐蚀、不易燃烧，抗张强度高，使用简单快捷；
工作温度范围：-40°C~85°C；
各种长度皆可制作，特殊规格可按客户样品制作。

Material: SS304, 316; PVC covered;
Features: high acid resistance, corrosion resistance and tensile strength; non-flammable; easy and convenient use;
Working temperature: -40°C~85°C;
Different lengths are available, special products can be made according to customer's sample.

型号 Item No.	规格 Specification (mm)	最大捆径 Max. Bundle Dia. (mm)	厚度 Thickness (mm)	包装 Packing
SY2-6-12200	12×200	42	1.2	100PCS/Bag
SY2-6-12300	12×300	77		
SY2-6-12400	12×400	108		
SY2-6-12500	12×500	138		
SY2-6-16300	16×300	76		50PCS/Bag
SY2-6-16400	16×400	108		
SY2-6-16500	16×500	138		
SY2-6-16600	16×600	172		
SY2-6-16800	16×800	232		

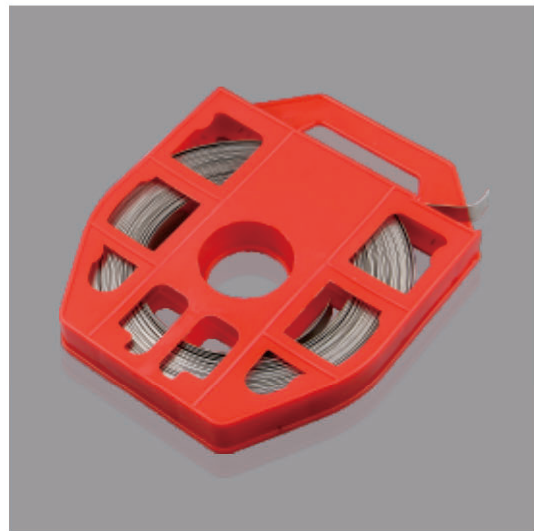

不锈钢包塑盘带

PVC COVERED STAINLESS STEEL BANDING

材质：采用不锈钢材质304, 316；外包PVC电缆料；
特性：耐酸、耐腐蚀、不易燃烧，抗张强度高，使用简单快捷；
工作温度范围：-40°C~85°C；
各种长度皆可制作，特殊规格可按客户样品制作。

Material: SS304, 316; PVC covered;
Features: high acid resistance, corrosion resistance and tensile strength; non-flammable; easy and convenient use;
Working temperature: -40°C~85°C;
Different lengths are available, special products can be made according to customer's sample.

型号 Item No.	宽度 Width		厚度 Thickness (mm)	配套搭扣 Matched Buckle	配套工具 Supporting Tool	包装数量 Packing Qty
	Inch	mm				
SY2-7-0930	3/8	9.0	1.2	L-10	LQA	30M
SY2-7-1225	1/2	12.0	1.2	L-12.0-12	LQA	25M
SY2-7-1625	5/8	16.0	1.2	L-16.0-16	LQA	25M



不锈钢包塑扎带-O型锁紧式

PVC COVERED STAINLESS STEEL CABLE TIE-O LOCK TYPE

材质：采用不锈钢材质304, 316；外包PVC电缆料；
特性：耐酸、耐腐蚀、不易燃烧，抗张强度高，使用简单快捷；
工作温度范围：-40°C~85°C；
各种长度皆可制作，特殊规格可按客户样品制作。

Material: SS304, 316; PVC covered;
Features: high acid resistance, corrosion resistance and tensile strength; non-flammable; easy and convenient use;
Working temperature: -40°C~85°C;
Different lengths are available, special products can be made according to customer's sample.

型号 Item No.	规格 Specification (mm)	最大捆径 Max. Bundle Dia. (mm)	厚度 Thickness (mm)	包装 Packing
SY2-8-12200	12×200	50	1.2	100PCS/Bag
SY2-8-12250	12×250	63		
SY2-8-12300	12×300	76		
SY2-8-12350	12×350	89		
SY2-8-12400	12×400	102		
SY2-8-12450	12×450	115		
SY2-8-12500	12×500	128		
SY2-8-12550	12×550	141		
SY2-8-12600	12×600	154		
SY2-8-12650	12×650	167		
SY2-8-12700	12×700	180		
SY2-8-16200	16×200	50		50PCS/Bag
SY2-8-16250	16×250	63		
SY2-8-16300	16×300	76		
SY2-8-16350	16×350	89		
SY2-8-16400	16×400	102		
SY2-8-16450	16×450	115		
SY2-8-16500	16×500	128		
SY2-8-16550	16×550	141		
SY2-8-16600	16×600	154		
SY2-8-16650	16×650	167		
SY2-8-16700	16×700	180		

STAINLESS STEEL CABLE TIE SERIES

不锈钢扎带系列

CE SGS RoHS c TÜV US E347821

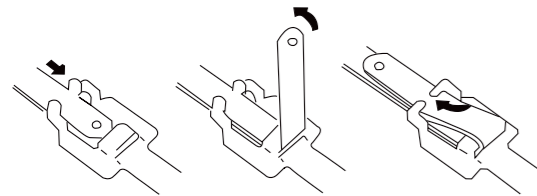
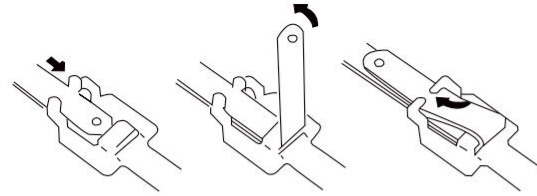

不锈钢扎带-可退式 RELEASABLE STAINLESS STEEL CABLE TIE

材质: 采用不锈钢材质304, 316;
特性: 高强度可退式扎带, 简单, 使用方便且可重复使用, 适用于电力, 通讯, 造船工业;
工作温度范围: -60°C~150°C.
Material: SS304, 316;
Features: high tensile strength; easy and convenient operation; can be re-used; suitable for electricity, telecommunication and shipbuilding industry;
Working temperature: -60°C~150°C.

型号 Item No.	规格 Specification (mm)	长度 Length		宽度 Width		最大捆径 Max. Bundle Dia.		拉力 Tensile Strength	
		Inch	mm	Inch	mm	Inch	mm	N	LBS
SY2-9-10150	10×150	5.9	150	0.39	10	1.3	33	1000	225
SY2-9-10190	10×190	7.5	190			1.8	46		
SY2-9-10250	10×250	9.8	250			2.6	65		
SY2-9-10300	10×300	11.8	300			3.2	81		
SY2-9-10350	10×350	13.8	350			3.8	97		
SY2-9-10400	10×400	15.7	400			4.4	113		
SY2-9-10450	10×450	17.7	450			5.1	129		
SY2-9-10490	10×490	19.3	490			5.6	141		
SY2-9-10550	10×550	21.7	550			6.3	161		
SY2-9-10600	10×600	23.6	600			6.9	176		
SY2-9-10650	10×650	25.6	650			7.6	192		
SY2-9-10700	10×700	27.6	700			8.2	208		

不锈钢喷塑扎带-可退式 RELEASABLE STAINLESS STEEL CABLE TIE-EPOXY TYPE

材质: 采用不锈钢材质304, 316; 外喷环氧树脂;
特性: 高强度可退式扎带, 简单, 使用方便且可重复使用, 适用于电力, 通讯, 造船工业
工作温度范围: -40°C~85°C.
Material: SS304, 316; Epoxy powder coated;
Features: high tensile strength; easy and convenient operation; can be re-used; suitable for electricity, telecommunication and shipbuilding industry;
Working temperature: -40°C~85°C.

型号 Item No.	规格 Specification (mm)	长度 Length		宽度 Width		最大捆径 Max. Bundle Dia.		拉力 Tensile Strength	
		Inch	mm	Inch	mm	Inch	mm	N	LBS
SY2-10-10150	10×150	5.9	150	0.39	10	1.3	33	1000	225
SY2-10-10190	10×190	7.5	190			1.8	46		
SY2-10-10250	10×250	9.8	250			2.6	65		
SY2-10-10300	10×300	11.8	300			3.2	81		
SY2-10-10350	10×350	13.8	350			3.8	97		
SY2-10-10400	10×400	15.7	400			4.4	113		
SY2-10-10450	10×450	17.7	450			5.1	129		
SY2-10-10490	10×490	19.3	490			5.6	141		
SY2-10-10550	10×550	21.7	550			6.3	161		
SY2-10-10600	10×600	23.6	600			6.9	176		
SY2-10-10650	10×650	25.6	650			7.6	192		
SY2-10-10700	10×700	27.6	700			8.2	208		



不锈钢扎带-阶梯型多重锁紧式 STAINLESS STEEL CABLE TIE-MULTI LOCK TYPE

材质: 采用不锈钢材质304, 316;
特性: 耐酸、耐腐蚀、抗张强度可达250磅; 室内外使用, 适用于通讯, 电力, 造船及输油管道工程上;
工作温度范围: -60°C~150°C.
Material: SS304, 316;
Features: high acid resistance, corrosion resistance and tensile strength; easy and convenient use;
Working temperature: -60°C~150°C.

型号 Item No.	规格 Specification (mm)	长度 Length		宽度 Width		最大捆径 M ax. Bundle Dia.		拉力 Tensile Strength	
		Inch	mm	Inch	mm	Inch	mm	N	LBS
SY2-11-07150	7×150	5.9	150	0.276	7	1.3	33	1120	252
SY2-11-07225	7×225	8.86	225			2.2	57		
SY2-11-07300	7×300	11.8	300			3.2	81		
SY2-11-07335	7×335	13.2	335			3.6	92		
SY2-11-07400	7×400	15.7	400			4.4	113		
SY2-11-07450	7×450	17.7	450			5.1	129		
SY2-11-07490	7×490	19.3	490			5.6	141		
SY2-11-07550	7×550	21.7	550			6.3	161		
SY2-11-07600	7×600	23.6	600			6.9	176		
SY2-11-07650	7×650	25.6	650			7.6	192		
SY2-11-07700	7×700	27.6	700			8.2	208		
SY2-11-07750	7×750	29.5	750			8.8	224		
SY2-11-07800	7×800	31.5	800			9.4	240		
SY2-11-12450	12×450	17.7	450			0.472	12		
SY2-11-12490	12×490	19.3	490	5.6	141				
SY2-11-12550	12×550	21.7	550	6.3	161				
SY2-11-12600	12×600	23.6	600	6.9	176				
SY2-11-12650	12×650	25.6	650	7.6	192				
SY2-11-12700	12×700	27.6	700	8.2	208				
SY2-11-12750	12×750	29.5	750	8.8	224				
SY2-11-12800	12×800	31.5	800	9.4	240				

STAINLESS STEEL CABLE TIE SERIES

不锈钢扎带系列



不锈钢喷塑扎带- 阶梯型多重锁紧式 EPOXY COATED STAINLESS STEEL CABLE TIE-MULTI LOCK TYPE

材质：采用不锈钢材质304, 316；外喷环氧树脂；
特性：耐酸、耐腐蚀、抗张强度可达250磅；室内外使用，适用于通讯，电力，造船及输油管道工程上；
工作温度范围：-40°C~85°C。

Material: SS304, 316; Epoxy power coated;
Features: high acid resistance, corrosion resistance and tensile strength; easy and convenient use;
Working temperature: -40°C~85°C.



型号 Item No.	规格 Specification (mm)	长度 Length		宽度 Width		最大捆径 Max. Bundle Dia.		拉力 Tensile Strength	
		Inch	mm	Inch	mm	Inch	mm	N	LBS
SY2-12-07150	7×150	5.9	150	0.276	7	1.3	33	1120	252
SY2-12-07225	7×225	8.86	225			2.2	57		
SY2-12-07300	7×300	11.8	300			3.2	81		
SY2-12-07335	7×335	13.2	335			3.6	92		
SY2-12-07400	7×400	15.7	400			4.4	113		
SY2-12-07450	7×450	17.7	450			5.1	129		
SY2-12-07490	7×490	19.3	490			5.6	141		
SY2-12-07550	7×550	21.7	550			6.3	161		
SY2-12-07600	7×600	23.6	600			6.9	176		
SY2-12-07650	7×650	25.6	650			7.6	192		
SY2-12-07700	7×700	27.6	700	8.2	208				
SY2-12-07750	7×750	29.5	750	8.8	224				
SY2-12-07800	7×800	31.5	800	9.4	240				
SY2-12-12450	12×450	17.7	450	0.472	12	5.1	129	1800	405
SY2-12-12490	12×490	19.3	490			5.6	141		
SY2-12-12550	12×550	21.7	550			6.3	161		
SY2-12-12600	12×600	23.6	600			6.9	176		
SY2-12-12650	12×650	25.6	650			7.6	192		
SY2-12-12700	12×700	27.6	700			8.2	208		
SY2-12-12750	12×750	29.5	750			8.8	224		
SY2-12-12800	12×800	31.5	800			9.4	240		

TIE TOOL SERIES

扎带工具系列

CE SGS RoHS US E347821



SYG01

适用于尼龙扎带宽2.4~4.8mm；
特点：将线束拉紧，适用于快速捆扎电线电缆；
重量：0.47kg；
材质：塑胶制品。

Suitable for nylon cable ties of width 2.4mm to 4.8mm
Feature: fast fastening cables and wires
Material: Plastic
Length: 145mm
Weight: 0.47kg



SYG02

适用于尼龙扎带宽度：2.4~4.8mm，长度在350mm以下；
特点：快速捆扎电线电缆，并自动切断扎带多余部分，捆剪一体，使用方便，高强度；
重量：0.3kg；
材质：金属制品。

Suitable for nylon cable ties of width 2.4mm to 4.8mm and length within 350mm;
Feature: Fast fastening wires and cables and automatically cut off the left part; simple to operate.
Material: Metal
Length: 165mm
Weight: 0.3kg



SYG03

适用于尼龙扎带宽度：2.4~4.8mm，长度在350mm以下；
特点：快速捆扎电线电缆，并自动切断扎带多余部分，捆剪一体，使用方便；
重量：0.3kg；
材质：塑胶制品。

Suitable for nylon cable ties of width 2.4mm to 4.8mm and length within 350mm;
Feature: Fast fastening wires and cables and automatically cut off the left part; simple to operate.
Material: Plastic
Length: 165mm
Weight: 0.3kg



SYG04

适用于尼龙扎带宽度：2.4~9.0mm，长度在500mm以下；
特点：快速捆扎电线电缆，并自动切断扎带多余部分，捆剪一体，使用方便，高强度；
重量：0.26kg；
材质：金属制品。

Suitable for nylon cable ties of width 2.4mm to 9.0mm and length within 500mm;
Feature: Fast fastening wires and cables and automatically cut off the left part; simple to operate.
Material: Metal
Length: 195mm
Weight: 0.26kg

TIE TOOL SERIES

扎带工具系列



LQG-1

适用于不锈钢扎带宽度：2.4~9.0mm；
特点：快速捆扎电缆电线，并自动切断扎带多余部分，捆剪一体，使用方便，高强度；
重量：0.595kg；
材质：金属制品。

Suitable for stainless steel cable ties of width 2.4mm to 9.0mm
Feature: Fast fastening wires and cables and automatically cut off the left part; simple to operate.
Material: Metal
Length: 205mm
Weight: 0.595kg



LQG-2

适用于不锈钢扎带宽度：2.4~4.8mm；
特点：快速捆扎电缆电线，捆剪一体，使用方便；
重量：0.3kg；
材质：塑胶制品。

Suitable for stainless steel cable ties of width 2.4mm to 4.8mm and length within 350mm;
Feature: Fast fastening wires and cables and cut off the left part; simple to operate.
Material: Metal
Length: 180mm
Weight: 0.3kg



LQA

适用于8mm-16mm的宽幅带子，具有抽紧及切断功能。

Suitable for stainless steel cable ties of width from 8mm to 16mm;
Feature: Easy cut off and remove the left ties, long life time
Material: Metal



JD1910

适用于10mm-25mm的宽幅带子，具有抽紧及切断功能。

Suitable for stainless steel cable ties of width from 10mm to 25mm;
Feature: Easy cut off and remove the left ties, long life time
Material: Metal

ELECTRICAL CONNECTOR SERIES

接线端子系列



ELECTRICAL CONNECTOR SERIES

接线端子系列

CE SGS RoHS cUL US E347821

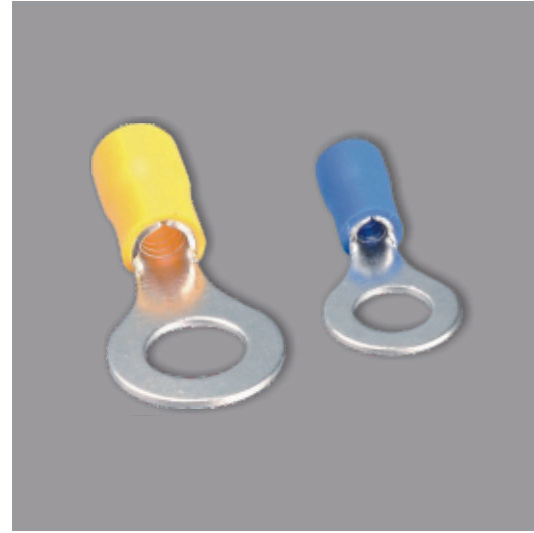

圆形预绝缘端头 INSULATED RING TERMINAL (RV SERIES)

型号 Model	美制螺丝号 American Bolt No.	d2Φ (mm)	尺寸 Dimension(mm)					颜色 Color
			B	L	F	H	DΦ	
RV 1.25-3	#4	3.2	5.7	17.8	4.95	10.0	4.3	Red
RVS 1.25-3.5	#6	3.7	5.7	17.8	4.95			
RVM 1.25-3.5	#6	3.7	6.6	20.1	6.3			
RVL 1.25-3.5	#6	4.3	8.0	21.5	7.0			
RVS 1.25-4	#8	4.3	6.6	20.1	6.3			
RV L 1.25-4	#8	4.3	8.0	21.5	7.0			
RV 1.25-5	#10	5.3	8.0	21.5	7.0			
RVL 1.25-5	#10	5.3	9.8	23.0	8.5			
RV 1.25-6	1/4	6.4	11.6	27.5	11.1			
RV 1.25-8	5/16	8.4	11.6	27.5	11.1			
RV 1.25-10	3/8	10.5	13.6	31.6	13.9			
RV 1.25-12	1/4	13.0	19.2	36.0	16.5			

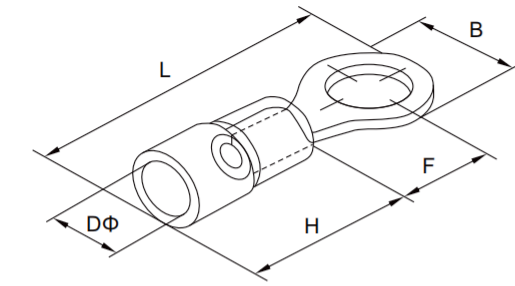

Red

导线截面: 0.5~1.5mm² (A.W.G 22~16); I_{max} = 19A;
材料: 铜; 厚度: 0.75mm。
Conductor section: 0.5~1.5mm² (A.W.G 22~16);
I_{max} = 19A; Material: copper; Thickness: 0.75mm.

Blue

导线截面: 1.5~2.5mm² (A.W.G 16~14); I_{max} = 27A;
材料: 铜; 厚度: 0.8mm。
Conductor section: 1.5~2.5mm² (A.W.G 16~14);
I_{max} = 27A; Material: copper; Thickness: 0.8mm.

Black

导线截面: 2.5~4mm² (A.W.G 14~12); I_{max} = 37A;
材料: 铜; 厚度: 1.0mm。
Conductor section: 2.5~4mm² (A.W.G 14~12);
I_{max} = 37A; Material: copper; Thickness: 1.0mm.

Yellow

导线截面: 4~6mm² (A.W.G 12~10); I_{max} = 48A;
材料: 铜; 厚度: 1.0mm。
Conductor section: 4~6mm² (A.W.G 12~10);
I_{max} = 48A; Material: copper; Thickness: 1.0mm.

RV 2-3	#4	3.2	6.6	17.8	4.3	10.0	4.9	Blue
RVS 2-3.5	#6	3.7	6.6	17.8	4.3			
RVM 2-3.5	#6	3.7	8.5	21.0	7.0			
RVL 2-3.5	#6	3.7	6.6	22.5	7.75			
RVS 2-4	#8	4.3	8.5	21.0	7.0			
RV L 2-4	#8	4.3	8.5	22.5	7.75			
RVS 2-5	#10	5.3	8.5	22.5	7.75			
RVL 2-5	#10	5.3	9.5	22.5	7.25			
RV 2-6	1/4	6.4	12.0	27.6	11.0			
RV 2-8	5/16	8.4	12.0	27.6	11.0			
RV 2-10	3/8	10.5	13.6	30.2	13.9			
RV 2-12	1/4	13.0	19.2	35.4	16.5			

RV 3.5-4	#8	4.3	8.0	24.5	7.7	13.0	6.2	Black
RVS 3.5-5	#10	5.3	8.0	24.65	7.7			
RVL 3.5-5	#10	5.3	12.0	27.9	7.7			
RV 3.5-6	1/4	6.4	12.0	27.9	7.7			

RV 5.5-3.5	#6	3.7	7.2	21.4	5.9	13.0	6.7	Yellow
RVS 5.5-4	#8	4.3	7.2	21.4	5.9			
RVL 5.5-4	#8	4.3	9.5	25.5	8.3			
RV 5.5-5	#10	5.3	9.5	25.5	8.3			
RV 5.5-6	1/4	6.4	12.0	31.5	13.0			
RV 5.5-8	5/16	8.4	15.0	33.7	13.7			
RV 5.5-10	3/8	10.5	15.0	33.7	13.7			
RV 5.5-12	1/2	13.0	19.2	38.1	16.0			



叉形绝缘端头 INSULATED SPADE TERMINAL (SV SERIES)

型号 Model	美制螺丝号 American Bolt No.	d2Φ (mm)	尺寸 Dimension(mm)					颜色 Color
			B	L	F	H	DΦ	
SV .25-3	#4	3.2	5.7	21.2	6.5	10.0	4.3	Red
SVS .25-3.5	#6	3.7	5.7	21.2	6.5			
SVL .25-3.5	#6	3.7	6.4	21.2	6.5			
SVS .25-4	#6	4.3	6.4	21.2	6.5			
SVM .25-4	#8	4.3	7.2	21.2	6.5			
SVL .25-4	#8	4.3	8.1	21.2	6.5			
SVS .25-5	#10	5.3	8.1	21.2	6.5			
SVL .25-5	#10	5.3	9.5	21.2	6.5			
SVS .25-6	1/4	6.4	9.5	21.2	6.5			
SVL .25-6	1/4	6.4	12.0	21.2	11.0			

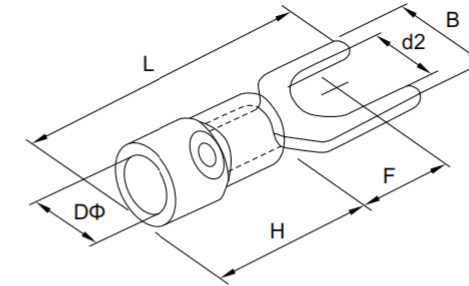

Red

导线截面: 0.5~1.5mm² (A.W.G 22~16); I_{max} = 19A;
材料: 铜; 厚度: 0.75mm。
Conductor section: 0.5~1.5mm² (A.W.G 22~16);
I_{max} = 19A; Material: copper; Thickness: 0.75mm.

Blue

导线截面: 1.5~2.5mm² (A.W.G 16~14); I_{max} = 27A;
材料: 铜; 厚度: 0.8mm。
Conductor section: 1.5~2.5mm² (A.W.G 16~14);
I_{max} = 27A; Material: copper; Thickness: 0.8mm.

Black

导线截面: 2.5~4mm² (A.W.G 14~12); I_{max} = 37A;
材料: 铜; 厚度: 1.0mm。
Conductor section: 2.5~4mm² (A.W.G 14~12);
I_{max} = 37A; Material: copper; Thickness: 1.0mm.

Yellow

导线截面: 4~6mm² (A.W.G 12~10); I_{max} = 48A;
材料: 铜; 厚度: 1.0mm。
Conductor section: 4~6mm² (A.W.G 12~10);
I_{max} = 48A; Material: copper; Thickness: 1.0mm.

SV -2	#4	3.2	5.7	21.2	6.5	10.0	4.9	Blue
SVS -2.5	#6	3.7	5.7	21.2	6.5			
SVL -2.5	#6	3.7	6.0	21.2	6.5			
SVS -2	#6	4.3	6.4	21.2	6.5			
SVM -2	#8	4.3	7.2	21.2	6.5			
SVL -2	#8	4.3	8.1	21.2	6.5			
SVS -2.5	#10	5.3	8.1	21.2	6.5			
SVL -2.5	#10	5.3	9.5	21.2	6.5			
SVS -2	1/4	6.4	9.5	21.2	6.5			
SVL -2	1/4	6.4	12.0	21.2	11.0			

SV .5-3	#4	3.2	5.7	24.8	7.0	13.0	6.2	Black
SV .5-4	#8	4.3	8.0	24.8	7.0			
SV .5-5	#10	5.3	8.0	24.8	7.0			
SV .5-6	1/4	6.4	12.0	28.0	12.1			

SV .5-3.5	#6	3.7	8.3	25.2	7.5	13.0	6.7	Yellow
SVS .5-4	#8	4.3	8.3	25.2	7.5			
SVL .5-4	#8	4.3	9.0	25.2	7.5			
SV .5-5	#10	5.3	9.0	25.2	7.5			
SVS .5-6	1/4	6.4	9.0	25.2	7.5			
SVL .5-6	1/4	6.4	12.0	31.2	12.0			
SV .5-8	5/16	8.4	14.0	30.0	11.5			

ELECTRICAL CONNECTOR SERIES

接线端子系列

CE SGS RoHS cUL US E347821



长形全绝缘中间接头 LONG FULL INSULATED MIDDLE JOINT TERMINAL (BUTT CONNECTOR BV SERIES)

材料：铜；绝缘材料：PVC。

Material: copper; Insulating material: PVC.

型号 Model	导线截面 Conductor Section		尺寸 Dimension(mm)			最大电流 I _{max}	颜色 Color
	A.W.G	mm ²	L	I	DΦ		
BV 1.25	22-16	0.5-1.5	15	1.7	26	19A	Red
BV 2	16-14	1.5-2.5	15	2.3	26	27A	Blue
BV 5.5	12-150	4-6	15	3.4	26	48A	Yellow
BV 22	#4	16-25	29	7.7	50	115A	Yellow
BV 38	#2	35-50	32	9.4	55	160A	Red

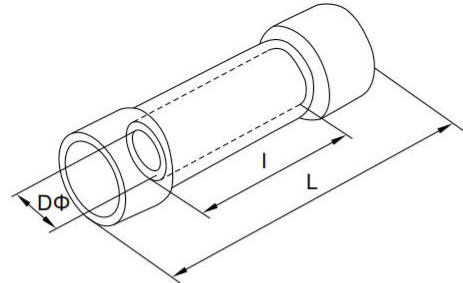

子弹型公预绝缘接头 BULLET-SHAPED MALE INSULATED TERMINAL (MPD SERIES)

导线截面：0.5~1.5mm² (A.W.G 22~16); I_{max} = 10A; 材料：黄铜。

Conductor section: 0.5~1.5mm² (A.W.G 22~16); I_{max}=10A; Material: brass.

型号 Model	材料厚度 Material Thickness (mm)	尺寸 Dimension(mm)					颜色 Color
		bΦ	F	DΦ	H	L	
MPD 1.25-156	0.4	4.0	11.0	1.7	10.0	21.0	Red

导线截面：1.5~2.5mm² (A.W.G 16~14); I_{max} = 15A; 材料：黄铜。

Conductor section: 1.5~2.5mm² (A.W.G 16~14); I_{max}=15A; Material: brass.

型号 Model	材料厚度 Material Thickness (mm)	尺寸 Dimension(mm)					颜色 Color
		bΦ	F	DΦ	H	L	
MPD 2-156	0.4	4.0	11.0	2.3	10.0	21.0	Blue
MPD 2-195	0.4	5.0	11.0	2.3	10.0	21.0	

导线截面：4~6mm² (A.W.G 12~10); I_{max} = 24A; 材料：黄铜。

Conductor section: 4~6mm² (A.W.G 12~10); I_{max}=24A; Material: brass.

型号 Model	材料厚度 Material Thickness (mm)	尺寸 Dimension(mm)					颜色 Color
		bΦ	F	DΦ	H	L	
MPD 5-195	0.4	5.0	12.0	3.4	13.0	25.0	Yellow

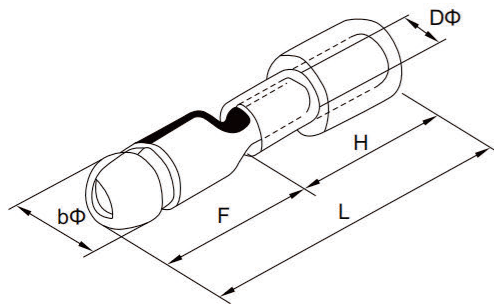

子弹型母预绝缘接头 BULLET-SHAPED FEMALE INSULATED TERMINAL (FRD SERIES)

导线截面：0.5~1.5mm² (A.W.G 22~16); I_{max} = 10A; 材料：黄铜。

Conductor section: 0.5~1.5mm² (A.W.G 22~16); I_{max}=10A; Material: brass.

型号 Model	材料厚度 Material Thickness (mm)	尺寸 Dimension(mm)					颜色 Color
		bΦ	F	DΦ	H	L	
FRD 1.25-156	0.4	4.0	6.3	1.7	13.0	24.5	Red

导线截面：1.5~2.5mm² (A.W.G 16~14); I_{max} = 15A; 材料：黄铜。

Conductor section: 1.5~2.5mm² (A.W.G 16~14); I_{max}=15A; Material: brass.

型号 Model	材料厚度 Material Thickness (mm)	尺寸 Dimension(mm)					颜色 Color
		bΦ	F	DΦ	H	L	
FRD 2-156	0.4	4.0	6.3	2.3	14.0	24.5	Blue
FRD 2-195	0.4	5.0	7.0	2.3	14.0	25.5	

导线截面：4~6mm² (A.W.G 12~10); I_{max} = 24A; 材料：黄铜。

Conductor section: 4~6mm² (A.W.G 12~10); I_{max}=24A; Material: brass.

型号 Model	材料厚度 Material Thickness (mm)	尺寸 Dimension(mm)					颜色 Color
		bΦ	F	DΦ	H	L	
FRD 5-195	0.4	5.0	7.0	3.4	14.0	29.5	Yellow

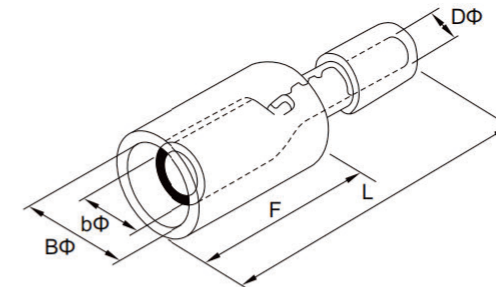

螺旋式压线帽 SCREW ON WIRE CONNECTOR

型号 Model	导线组合范围 Conductor Range	尺寸 Dimension(mm)			颜色 Color
		B	C	L	
SP1	Min: 0.75×1+0.5×1 Max: 1.5×2	8.5	6.7	15	Gray
SP2	Min: 0.75×3 Max: 1.5×3	10.1	7.4	17.5	Blue
SP3	Min: 0.75×3 Max: 1.5×3+1×1	12.6	9.9	22.1	Orange
SP4	Min: 0.25×1+0.75×1 Max: 2.5×4+0.75×1	13.7	11	24.5	Yellow
SP6	Min: 0.25×2 Max: 6×2+4×2	16	13	26.5	Red

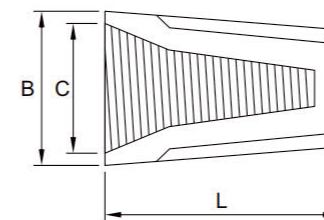

ELECTRICAL CONNECTOR SERIES

接线端子系列



超值包装 VALUE PACK

N-175(plastic box); 175PCS, 18 Type Assortment

型号 Item No.	数量 Qty	型号 Item No.	数量 Qty	型号 Item No.	数量 Qty
RV1.25-3	15	RV5.5-5	5	BV2	10
RVS1.25-4	10	RV5.5-6	5	BV5.5	5
RV1.25-5	10	SV1.25-3	10	MDD1.25-250	10
RV2-3	15	SVS1.25-4	10	MDD2-250	10
RVS2-4	10	SVL2-4	10	FDD1.25-250	10
RVL2-5	10	BV1.25	10	FDD2-250	10

N-300(plastic box); 300PCS, 18 Type Assortment

型号 Item No.	数量 Qty	型号 Item No.	数量 Qty	型号 Item No.	数量 Qty
RV1.25-3	25	RV5.5-5	5	BV2	10
RVS1.25-4	25	RV5.5-6	5	BV5.5	5
RV1.25-5	25	SV1.25-3	20	MDD1.25-250	20
RV2-3	15	SVS1.25-4	20	MDD2-250	20
RVS2-4	20	SVL2-4	20	FDD1.25-250	20
RVL2-5	10	BV1.25	10	FDD2-250	20

N-760(plastic box); 760PCS, 18 Type Assortment

型号 Item No.	数量 Qty	型号 Item No.	数量 Qty	型号 Item No.	数量 Qty
RV1.25-3	80	RV5.5-5	40	BV2	20
RVS1.25-4	80	RV5.5-6	40	BV5.5	40
RV1.25-5	80	SV1.25-3	80	MDD1.25-250	40
RV2-3	80	SVS1.25-4	80	MDD2-250	40
RVS2-4	10	SVL2-4	10	FDD1.25-250	10
RVL2-5	10	BV1.25	10	FDD2-250	10

N-1200(plastic box); 1200PCS, 18 Type Assortment

型号 Item No.	数量 Qty	型号 Item No.	数量 Qty	型号 Item No.	数量 Qty
RV1.25-3	80	RV5.5-5	40	BV2	50
RVS1.25-4	80	RV5.5-6	40	BV5.5	40
RV1.25-5	80	SV1.25-3	80	MDD1.25-250	70
RV2-3	80	SVS1.25-4	80	MDD2-250	70
RVS2-4	80	SVL2-4	80	FDD1.25-250	70
RVL2-5	60	BV1.25	50	FDD2-250	70



OTHER SERIES

其他系列





螺丝固定座 Saddle Type Tie Mount

材料：UL 认证尼龙 66,94V-2;

颜色：自然色，其他颜色可选;

鞍座设计为线束提供最大的稳定性。应用时，只需用螺丝固定底座并用尼龙束线带固定线束。

Material: UL approved Nylon 66, 94V-2;

Color: Natural, available in other colors;

Saddle design provide maximun stability to wire bundles. To apply, simply fix mount with a screw and secure wire bundles with Nylon cable ties.

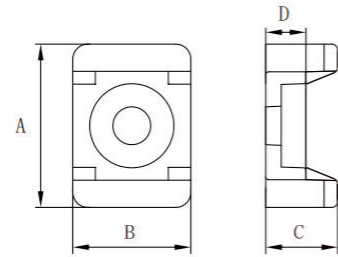

型号 Item No.	A (mm)	B (mm)	C (mm)	D (mm)
SYE-5D	21.6	15.6	9.5	5



自粘式定位片

SELF-ADHESIVE TIE MOUNTS

材质：塑件可为尼龙66或ABS，背附进口海绵胶，有普通胶水和3M胶水，绝缘性能好，耐久性，不易老化;

使用方法：将定位片背面双面胶揭开，贴于机板固定，稍许片刻，再用扎带捆扎电线即可;

特点：省时，简便，供面板不可以钻孔时使用。

Material: Plastic part can be Nylon 66 or ABS; with imported adhesive sticker;

Usage: Peel the sponge glue and stick on the wall then, bundle the wire with cable ties;

Features: used for hole-drilling not allowed places; save time, simple operation.

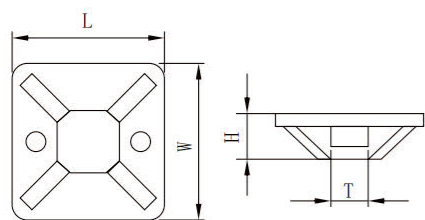

型号 Item No.	长L×宽W Length×Width (mm)	高H (mm)	螺丝孔 Screw Hole (mm)	包装 Packing
SYS-20	20×20	6.1	2.9	100PCS
SYS-25	25×25	7.5	3.5	
SYS-30	30×30	8.7	4.5	
SYS-40	40×40	11.5	4.5	



圆形号码管

CIRCULAR CABLE MARKERS

材质：采用优质PVC制成，能防止油炸及其他物质侵蚀，耐高温85℃;

构造：号码管内部成凹型，具有弹性。内径能随着电线大小而伸缩。

Material: Made from PVC; oil and erosion control, heat resisting up to 85℃;

Structure: The inside is hollow, but elastic, the diameter can change with the needed wire.

型号 Item No.	适用电线 Approx Wire		号码 Markers	包装 Packing
	SQ	mm		
EC-0	0.75~1.5	2.0~3.2	0~9; A~Z; + - / \	1000PCS/Roll
EC-1	0.75~3.5	3.0~4.2		1000PCS/Roll
EC-2	3.5~8.0	3.6~7.4		500PCS/Roll
EC-3	5.2~10.0	5.2~10.0		350PCS/Roll



扁形号码管

FLAT CABLE MARKERS

材质：采用优质PVC制成，能防止油性及其他物质侵蚀;

特点：适用于线径3.5mm到7.0mm之圆线或扁线用。

Material: Made from PVC; oil and erosion control;

Feature: Used for circle of flat wire size from 3.5mm-7.0mm.

型号 Item No.	适用电线 Approx Wire		号码 Markers	包装 Packing
	SQ	mm		
EC-J	3.5~7.0	0.5~7.0	0~9; A~Z; + - / \	500PCS/Roll



号码管带

CABLE MARKER STRIPS

材质：采用UL认可NYLON66制成，防火等级94V-2，绝缘性能良好，耐久且不易老化;

构造：为长方条形，两端各有两个带孔。

Material: use Nylon 66. 94V-2 certificated UL, with well insulation and not easily aging;

Construction: be rectangular bar, with hole on both ends.

型号 Item No.	长 Length (mm)	宽 Width (mm)	包装 Packing
MS-65	65	9	100PCS/Bag
MS-100	100		
MS-135	135		



圆型(K型)钢钉线卡 CIRCLE CABLECLIPS (K TYPE)

材质：采用PE或PP料制成，附钢钉；
 使用方法：将电线至于卡内，用铁锤将钢钉钉于墙壁即可将线缆固定；
 用途：一般室内配固定线缆用。
 Material: PE or PP, with steel nail;
 Application: Put the cable under the clip and hammer the nail into wall to fix the cable.

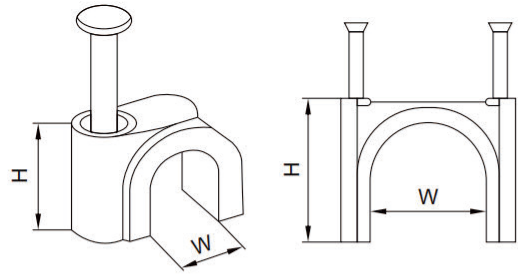

扁型钢钉线卡 FLAT CABLE CLIPS

材质：采用PE或PP料制成，附钢钉；
 使用方法：将电线至于卡内，用铁锤将钢钉钉于墙壁即可将线缆固定；
 用途：一般室内配固定线缆用。
 Material: PE or PP, with steel nail;
 Application: Put the cable under the clip and hammer the nail into wall to fix the cable.

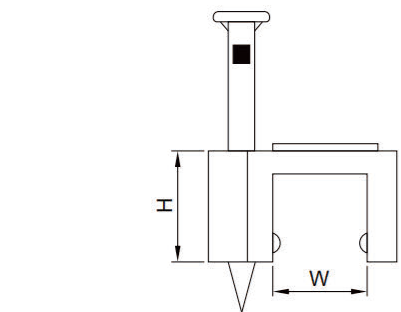

型号 Item No.	长 Length (mm)	宽 Width (mm)	钢钉 Nail (mm)
HRK-4MM	6.2	3.5	1.7×14
HRK-5MM	7.6	4.5	1.7×14
HRK-6MM	8.5	5.5	1.8×17
HRK-7MM	10.5	6.5	1.8×18
HRK-8MM	11	8	1.9×19
HRK-9MM	11.6	9	2.0×21
HRK-10MM	11.6	9.5	2.0×22
HRK-12MM	15.1	11	2.1×25
HRK-14MM	17	13.5	2.2×27
HRK-16MM	19	15.5	2.3×30
HRK-18MM	20.8	17	2.5×35
HRK-20MM	22.2	18	2.8×38
HRK-22MM	24.1	21.5	3.0×42
HRK-25MM	27.1	23	3.0×45
HRK-30MM	33.1	30	3.0×52
HRK-32MM	35	32	3.0×52
HRK-35MM	36.6	35	3.0×57
HRK-40MM	45.2	40	3.0×60

型号 Item No.	长 Length (mm)	宽 Width (mm)	钢钉 Nail (mm)
HRF-4MM	5.2	3.8	1.7×14
HRF-5MM	5.8	4.8	1.7×14
HRF-6MM	6.2	5.5	1.8×16
HRF-7MM	7	6.5	1.8×16
HRF-8MM	7.9	7.5	1.8×16
HRF-9MM	8.3	8.5	2.0×17
HRF-10MM	8.3	9.5	2.0×17
HRF-12MM	8.3	11.5	2.0×20
HRF-14MM	8.5	13.2	2.0×20
HRF-16MM	11	15	2.0×25



**卷式结束保护带 (缠绕管)
SPIRAL WRAPPING BANDS**

材质：PE；
 使用方法：先用保护带固定起点一端，多面手按顺时针方向环绕束紧，即可将电线束为一体；
 特点：作为保护电线不受磨损及绝缘用，并可改进电线弯曲的美观。
 Material: PE;
 Usage: Fix one end with safety belt first, and then circle the wires clock wised to make them tighten;
 Features: Protect the wires from wear and for insulation; improve the appearance of wires.

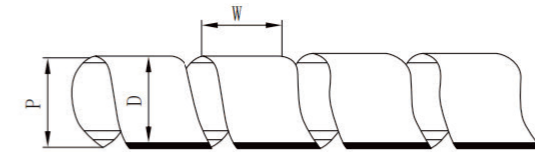

型号 Item No.	内径P (mm)	外径D (mm)	螺距W (mm)	捆扎范围 Wire Range (mm)	包装 Packing
SYB-06	4	6	7.0	4-50	10m/roll
SYB-08	6	8	10.8	6-60	
SYB-10	7.5	10	11.4	7.5-60	
SYB-12	9	12	13.9	9-65	
SYB-15	12	15	15.0	12-70	
SYB-19	15	19	18.2	15-100	
SYB-24	20	24	19.6	20-130	



膨胀管 Expand Plugs

膨胀管的几何形状，在物体的实体结构中膨胀；
 防止旋转的结构设计，使用时螺杆在空气中不旋转跟随；
 材质：PE；
 颜色：以灰色和白色为主，也可提供其他颜色。
 Geometry of the expansion pipe, in the solidstructure of the objectin the expansion;
 To prevent rotation of the structural design, when using the screw does not rotate in the airto follow;
 Material: PE;
 Color: Mostly grey and white, other colors arealso available.

型号 Item No.	长 Length (mm)	外径 Out Diameter (mm)	内径 Inner Diameter (mm)
SYEP-04	20	4	3
SYEP-06	30	6	4.4
SYEP-07	35	7	5
SYEP-08	40	8	6
SYEP-10	50	10	7.9
SYEP-12	60	12	9.6